

PHILIPPINE INTERNATIONAL CONVENTION CENTER



BIDDING DOCUMENTS

**PROJECT TITLE : SUPPLY AND INSTALLATION OF ONE (1) 50-TR
DIRECT EXPANSION-TYPE PACKAGED AIR
HANDLING UNIT AS REPLACEMENT OF THE
OLD/EXISTING UNIT SERVING MEETING
ROOM 1**

ABC : ₱5,050,000.00

Reference/s : PICC APP2025- MC - 52

**ITB-2025
March 10, 2025**

TABLE OF CONTENTS

Glossary of Terms, Abbreviations, and Acronyms	3
Section I. Invitation to Bid	6
Section II. Instruction to Bidders	9
1. Scope of Bid	10
2. Funding Information	10
3. Bidding Requirements	10
4. Corrupt, Fraudulent, Collusive and Coercive Practices	10
5. Eligible Bidders	10
6. Origin of Goods.....	11
7. Subcontracts	11
8. Pre-bid Conference	12
9. Clarification and Amendments of Bidding Documents	12
10. Documents Comprising the Bid: Eligibility and Technical Component	12
11. Documents Comprising the Bid: Financial Component	12
12. Bid Prices	13
13. Bid and Payment Currencies	13
14. Bid Security	14
15. Sealing and Marking of Bids	14
16. Deadline for Submission of Bids	14
17. Opening and Preliminary Examination of Bids	14
18. Domestic Preference	14
19. Detailed Evaluation and Comparison of Bids	15
20. Post Qualification	15
21. Signing of the Contract	15
Section III. Bid Data Sheet	16
Section IV. General Conditions of Contract	20
1. Scope of Contract	21
2. Advance Payment and Terms of Payment.....	21
3. Performance Security	21
4. Inspection and Test	21
5. Warranty	22
6. Liability of the Supplier.....	22
Section V. Special Conditions of Contract	23
Section VI. Schedule of Requirements	29
Section VII. Technical Specifications	30
Section VIII. Checklist of Technical and Financial Documents	31

Glossary of Acronyms, Terms, and Abbreviations

ABC – Approved Budget for the Contract.

BAC – Bids and Awards Committee.

Bid – A signed offer or proposal to undertake a contract submitted by a bidder in response to and in consonance with the requirements of the bidding documents. Also referred to as *Proposal* and *Tender*. (2016 revised IRR, Section 5[c])

Bidder – Refers to a contractor, manufacturer, supplier, distributor and/or consultant who submits a bid in response to the requirements of the Bidding Documents. (2016 revised IRR, Section 5[d])

Bidding Documents – The documents issued by the Procuring Entity as the bases for bids, furnishing all information necessary for a prospective bidder to prepare a bid for the Goods, Infrastructure Projects, and/or Consulting Services required by the Procuring Entity. (2016 revised IRR, Section 5[e])

BIR – Bureau of Internal Revenue.

BSP – Bangko Sentral ng Pilipinas.

Consulting Services – Refer to services for Infrastructure Projects and other types of projects or activities of the GOP requiring adequate external technical and professional expertise that are beyond the capability and/or capacity of the GOP to undertake such as, but not limited to: (i) advisory and review services; (ii) pre-investment or feasibility studies; (iii) design; (iv) construction supervision; (v) management and related services; and (vi) other technical services or special studies. (2016 revised IRR, Section 5[i])

CDA - Cooperative Development Authority.

Contract – Refers to the agreement entered into between the Procuring Entity and the Supplier or Manufacturer or Distributor or Service Provider for procurement of Goods and Services; Contractor for Procurement of Infrastructure Projects; or Consultant or Consulting Firm for Procurement of Consulting Services; as the case may be, as recorded in the Contract Form signed by the parties, including all attachments and appendices thereto and all documents incorporated by reference therein.

CIF – Cost Insurance and Freight.

CIP – Carriage and Insurance Paid.

CPI – Consumer Price Index.

DDP – Refers to the quoted price of the Goods, which means “delivered duty paid.”

DTI – Department of Trade and Industry.

EXW – Ex works.

FCA – “Free Carrier” shipping point.

FOB – “Free on Board” shipping point.

Foreign-funded Procurement or Foreign-Assisted Project– Refers to procurement whose funding source is from a foreign government, foreign or international financing institution as specified in the Treaty or International or Executive Agreement. (2016 revised IRR, Section 5[b]).

Framework Agreement – Refers to a written agreement between a procuring entity and a supplier or service provider that identifies the terms and conditions, under which specific purchases, otherwise known as “Call-Offs,” are made for the duration of the agreement. It is in the nature of an option contract between the procuring entity and the bidder(s) granting the procuring entity the option to either place an order for any of the goods or services identified in the Framework Agreement List or not buy at all, within a minimum period of one (1) year to a maximum period of three (3) years. (GPPB Resolution No. 27-2019)

GFI – Government Financial Institution.

GOCC – Government-owned and/or –controlled corporation.

Goods – Refer to all items, supplies, materials and general support services, except Consulting Services and Infrastructure Projects, which may be needed in the transaction of public businesses or in the pursuit of any government undertaking, project or activity, whether in the nature of equipment, furniture, stationery, materials for construction, or personal property of any kind, including non-personal or contractual services such as the repair and maintenance of equipment and furniture, as well as trucking, hauling, janitorial, security, and related or analogous services, as well as procurement of materials and supplies provided by the Procuring Entity for such services. The term “related” or “analogous services” shall include, but is not limited to, lease or purchase of office space, media advertisements, health maintenance services, and other services essential to the operation of the Procuring Entity. (2016 revised IRR, Section 5[r])

GOP – Government of the Philippines.

GPPB – Government Procurement Policy Board.

INCOTERMS – International Commercial Terms.

Infrastructure Projects – Include the construction, improvement, rehabilitation, demolition, repair, restoration or maintenance of roads and bridges, railways, airports, seaports, communication facilities, civil works components of information technology projects, irrigation, flood control and drainage, water supply, sanitation, sewerage and solid waste management systems, shore protection, energy/power and electrification facilities, national

buildings, school buildings, hospital buildings, and other related construction projects of the government. Also referred to as *civil works or works*. (2016 revised IRR, Section 5[u])

LGUs – Local Government Units.

NFCC – Net Financial Contracting Capacity.

NGA – National Government Agency.

PhilGEPS - Philippine Government Electronic Procurement System.

Procurement Project – refers to a specific or identified procurement covering goods, infrastructure project or consulting services. A Procurement Project shall be described, detailed, and scheduled in the Project Procurement Management Plan prepared by the agency which shall be consolidated in the procuring entity's Annual Procurement Plan. (GPPB Circular No. 06-2019 dated 17 July 2019)

PSA – Philippine Statistics Authority.

SEC – Securities and Exchange Commission.

SLCC – Single Largest Completed Contract.

Supplier – refers to a citizen, or any corporate body or commercial company duly organized and registered under the laws where it is established, habitually established in business and engaged in the manufacture or sale of the merchandise or performance of the general services covered by his bid. (Item 3.8 of GPPB Resolution No. 13-2019, dated 23 May 2019). Supplier as used in these Bidding Documents may likewise refer to a distributor, manufacturer, contractor, or consultant.

UN – United Nations.

Section I. Invitation to Bid



BIDS AND AWARDS COMMITTEE

Invitation to Bid for the Supply and Installation of One (1) 50-TR Direct Expansion Type Packaged Air Handling Unit as Replacement of the Old/Existing Unit Serving Meeting Room 1

1. The *Philippine International Convention Center (PICC)*, through the *Approved Budget for CY 2025*, intends to apply the sum of **FIVE MILLION FIFTY THOUSAND PESOS (Php5,050,000.00)**, **VAT Inclusive**, being the Approved Budget for the Contract (ABC) to payments under the contract for the **Supply and Installation of One (1) 50-TR Direct Expansion Type Packaged Air Handling Unit as Replacement of the Old/Existing Unit Serving Meeting Room 1 (PICC APP2025-MC-52)**. Bids received in excess of ABC shall be automatically rejected at bid opening.
2. The *PICC* now invites bids for the abovementioned requirement. Bidders should have completed, within three (3) years from the date of submission and receipt of bids, a contract similar to the abovementioned requirement. The description of an eligible bidder is contained in the Bidding Documents, particularly, in Section II (Instructions to Bidders).
3. Bidding will be conducted through open competitive bidding procedures using a non-discretionary "*pass/fail*" criterion as specified in the 2016 Revised Implementing Rules and Regulations (IRR) of Republic Act (RA) No. 9184.
4. Prospective Bidders may obtain further information from the *PICC-BAC* and inspect the Bidding Documents at the address given below during office hours.
5. A complete set of Bidding Documents may be acquired by prospective bidders starting **April 05, 2025** from the given address and website(s) below *and upon payment of a non-refundable fee in the amount of Six Thousand Pesos (Php6,000.00)*. A bidder shall present its proof of payment for the fee *by furnishing the PICC-BAC a copy of the Official Receipt*.
6. The *PICC-BAC* will hold a Pre-Bid Conference on **April 22, 2025 at 11:00 a.m. at Function Room B, 2nd Floor Secretariat Building, PICC** and/or through videoconferencing/webcasting *via Zoom/Google Meet*, which shall be open to prospective bidders (see interim guidelines for conduct of video conferencing).
7. Bids must be duly received by the BAC Secretariat through manual submission at the office address indicated below, on or before **May 05, 2025 at 10:30 a.m.** Late bids shall not be accepted.
8. All Bids must be accompanied by a bid security in any of the acceptable forms and in the amount stated in **ITB Clause 14**.

9. Bid opening shall be on **May 05, 2025, at 11:00 a.m.** at the given address below. Bids will be opened in the presence of the bidders' representatives who choose to attend the activity via video conferencing.
10. The *PICC* reserves the right to reject any and all bids, declare a failure of bidding, or not award the contract at any time prior to contract award in accordance with Sections 35.6 and 41 of the 2016 revised IRR of RA No. 9184, without thereby incurring any liability to the affected bidder or bidders.
11. For further information, please refer to:

*BIDS AND AWARDS COMMITTEE
PHILIPPINE INTERNATIONAL CONVENTION CENTER
PICC Complex, Pasay City 1307
87894759 and 87894760
Telefax No. 87894761
Email: procurement@picc.gov.ph*

12. You may visit the following websites:

For downloading of Bidding Documents: www.picc.gov.ph

[Date of Issue]

MELAN M. ESPELA
Chairperson
2/2/25

Section II. Instructions to Bidders

1. Scope of Bid

The Procuring Entity, *Philippine International Convention Center* wishes to receive Bids for the *Supply and Installation of One (1) 50-TR Direct Expansion Type Packaged Air Handling Unit as Replacement of the Old/Existing Unit Serving Meeting Room 1* with identification numbers *PICC APP2025-MC-52*.

2. Funding Information

- 2.1. The GOP through the source of funding as indicated below for 2025 in the total amount of PhP5,050,000.00.
- 2.2. The source of funding is:
 - a. GOCC and GFIs, the Corporate Operating Budget.

3. Bidding Requirements

The Bidding for the Project shall be governed by all the provisions of RA No. 9184 and its 2016 revised IRR, including its Generic Procurement Manuals and associated policies, rules and regulations as the primary source thereof, while the herein clauses shall serve as the secondary source thereof.

Any amendments made to the IRR and other GPPB issuances shall be applicable only to the ongoing posting, advertisement, or **IB** by the BAC through the issuance of a supplemental or bid bulletin.

The Bidder, by the act of submitting its Bid, shall be deemed to have verified and accepted the general requirements of this Project, including other factors that may affect the cost, duration and execution or implementation of the contract, project, or work and examine all instructions, forms, terms, and project requirements in the Bidding Documents.

4. Corrupt, Fraudulent, Collusive, and Coercive Practices

The Procuring Entity, as well as the Bidders and Suppliers, shall observe the highest standard of ethics during the procurement and execution of the contract. They or through an agent shall not engage in corrupt, fraudulent, collusive, coercive, and obstructive practices defined under Annex "I" of the 2016 revised IRR of RA No. 9184 or other integrity violations in competing for the Project.

5. Eligible Bidders

- 5.1. Only Bids of Bidders found to be legally, technically, and financially capable will be evaluated.
- 5.2. Foreign ownership limited to those allowed under the rules may participate in this Project.

- 5.3. Pursuant to Section 23.4.1.3 of the 2016 revised IRR of RA No.9184, the Bidder shall have an SLCC that is at least one (1) contract similar to the Project the value of which, adjusted to current prices using the PSA's CPI, must be at least equivalent to:
 - a. For the procurement of Non-expendable Supplies and Services: The Bidder must have completed a single contract that is similar to this Project, equivalent to at least fifty percent (50%) of the ABC.
- 5.4. The Bidders shall comply with the eligibility criteria under Section 23.4.1 of the 2016 IRR of RA No. 9184.

6. Origin of Goods

There is no restriction on the origin of goods other than those prohibited by a decision of the UN Security Council taken under Chapter VII of the Charter of the UN, subject to Domestic Preference requirements under **ITB** Clause 18.

7. Subcontracts

- 7.1. The Bidder may subcontract portions of the Project to the extent allowed by the Procuring Entity as stated herein, but in no case more than twenty percent (20%) of the Project.

The Procuring Entity has prescribed that:

- a. Subcontracting is not allowed.
- 7.2. *[If Procuring Entity has determined that subcontracting is allowed during the bidding, state:]* The Bidder must submit together with its Bid the documentary requirements of the subcontractor(s) complying with the eligibility criteria stated in **ITB** Clause 5 in accordance with Section 23.4 of the 2016 revised IRR of RA No. 9184 pursuant to Section 23.1 thereof.
 - 7.3. *[If subcontracting is allowed during the contract implementation stage, state:]* The Supplier may identify its subcontractor during the contract implementation stage. Subcontractors identified during the bidding may be changed during the implementation of this Contract. Subcontractors must submit the documentary requirements under Section 23.1 of the 2016 revised IRR of RA No. 9184 and comply with the eligibility criteria specified in **ITB** Clause 5 to the implementing or end-user unit.
 - 7.4. Subcontracting of any portion of the Project does not relieve the Supplier of any liability or obligation under the Contract. The Supplier will be responsible for the acts, defaults, and negligence of any subcontractor, its agents, servants, or workmen as fully as if these were the Supplier's own acts, defaults, or negligence, or those of its agents, servants, or workmen.

8. Pre-Bid Conference

The Procuring Entity will hold a pre-bid conference for this Project on the specified date and time and either at its physical address at and/or through videoconferencing/webcasting as indicated in paragraph 6 of the **IB**.

9. Clarification and Amendment of Bidding Documents

Prospective bidders may request for clarification on and/or interpretation of any part of the Bidding Documents. Such requests must be in writing and received by the Procuring Entity, either at its given address or through electronic mail indicated in the **IB**, at least ten (10) calendar days before the deadline set for the submission and receipt of Bids.

10. Documents comprising the Bid: Eligibility and Technical Components

- 10.1. The first envelope shall contain the eligibility and technical documents of the Bid as specified in **Section VIII (Checklist of Technical and Financial Documents)**.
- 10.2. The Bidder's SLCC as indicated in **ITB Clause 5.3** should have been completed within the last three (3) years prior to the deadline for the submission and receipt of bids.
- 10.3. If the eligibility requirements or statements, the bids, and all other documents for submission to the BAC are in foreign language other than English, it must be accompanied by a translation in English, which shall be authenticated by the appropriate Philippine foreign service establishment, post, or the equivalent office having jurisdiction over the foreign bidder's affairs in the Philippines. Similar to the required authentication above, for Contracting Parties to the Apostille Convention, only the translated documents shall be authenticated through an apostille pursuant to GPPB Resolution No. 13-2019 dated 23 May 2019. The English translation shall govern, for purposes of interpretation of the bid.

11. Documents comprising the Bid: Financial Component

- 11.1. The second bid envelope shall contain the financial documents for the Bid as specified in **Section VIII (Checklist of Technical and Financial Documents)**.
- 11.2. If the Bidder claims preference as a Domestic Bidder or Domestic Entity, a certification issued by DTI shall be provided by the Bidder in accordance with Section 43.1.3 of the 2016 revised IRR of RA No. 9184.
- 11.3. Any bid exceeding the ABC indicated in paragraph 1 of the **IB** shall not be accepted.
- 11.4. For Foreign-funded Procurement, a ceiling may be applied to bid prices provided the conditions are met under Section 31.2 of the 2016 revised IRR of RA No. 9184.

12. Bid Prices

- 12.1. Prices indicated on the Price Schedule shall be entered separately in the following manner:
- a. For Goods offered from within the Procuring Entity's country:
 - i. The price of the Goods quoted EXW (ex-works, ex-factory, ex-warehouse, ex-showroom, or off-the-shelf, as applicable);
 - ii. The cost of all customs duties and sales and other taxes already paid or payable;
 - iii. The cost of transportation, insurance, and other costs incidental to delivery of the Goods to their final destination; and
 - iv. The price of other (incidental) services, if any, listed in e.
 - b. For Goods offered from abroad:
 - i. Unless otherwise stated in the **BDS**, the price of the Goods shall be quoted delivered duty paid (DDP) with the place of destination in the Philippines as specified in the **BDS**. In quoting the price, the Bidder shall be free to use transportation through carriers registered in any eligible country. Similarly, the Bidder may obtain insurance services from any eligible source country.
 - ii. The price of other (incidental) services, if any, as listed in **Section VII (Technical Specifications)**.

13. Bid and Payment Currencies

- 13.1. For Goods that the Bidder will supply from outside the Philippines, the bid prices may be quoted in the local currency or tradeable currency accepted by the BSP at the discretion of the Bidder. However, for purposes of bid evaluation, Bids denominated in foreign currencies, shall be converted to Philippine currency based on the exchange rate as published in the BSP reference rate bulletin on the day of the bid opening.
- 13.2. Payment of the contract price shall be made in:
- a. Philippine Pesos.

14. Bid Security

- 14.1. The Bidder shall submit a Bid Securing Declaration¹ or any form of Bid Security in the amount indicated in the **BDS**, which shall be not less than the percentage of the ABC in accordance with the schedule in the **BDS**.
- 14.2 The Bid and bid security shall be valid one hundred twenty (120) calendar days from the date of opening of bids. Any Bid not accompanied by an acceptable bid security shall be rejected by the Procuring Entity as non-responsive.

15. Sealing and Marking of Bids

Each Bidder shall submit one copy of the first and second components of its Bid.

The Procuring Entity may request additional hard copies and/or electronic copies of the Bid. However, failure of the Bidders to comply with the said request shall not be a ground for disqualification.

If the Procuring Entity allows the submission of bids through online submission or any other electronic means, the Bidder shall submit an electronic copy of its Bid, which must be digitally signed. An electronic copy that cannot be opened or is corrupted shall be considered non-responsive and, thus, automatically disqualified.

16. Deadline for Submission of Bids

- 16.1. The Bidders shall submit on the specified date and time and either at its physical address or through online submission as indicated in paragraph 7 of the **IB**.

17. Opening and Preliminary Examination of Bids

- 17.1. The BAC shall open the Bids in public at the time, on the date, and at the place specified in paragraph 9 of the **IB**. The Bidders' representatives who are present shall sign a register evidencing their attendance. In case videoconferencing, webcasting or other similar technologies will be used, attendance of participants shall likewise be recorded by the BAC Secretariat.

In case the Bids cannot be opened as scheduled due to justifiable reasons, the rescheduling requirements under Section 29 of the 2016 revised IRR of RA No. 9184 shall prevail.

- 17.2. The preliminary examination of bids shall be governed by Section 30 of the 2016 revised IRR of RA No. 9184.

¹ In the case of Framework Agreement, the undertaking shall refer to entering into contract with the Procuring Entity and furnishing of the performance security or the performance securing declaration within ten (10) calendar days from receipt of Notice to Execute Framework Agreement.

18. Domestic Preference

- 18.1. The Procuring Entity will grant a margin of preference for the purpose of comparison of Bids in accordance with Section 43.1.2 of the 2016 revised IRR of RA No. 9184.

19. Detailed Evaluation and Comparison of Bids

- 19.1. The Procuring BAC shall immediately conduct a detailed evaluation of all Bids rated "*passed*," using non-discretionary pass/fail criteria. The BAC shall consider the conditions in the evaluation of Bids under Section 32.2 of the 2016 revised IRR of RA No. 9184.
- 19.2. Except for bidders submitting a committed Line of Credit from a Universal or Commercial Bank in lieu of its NFCC computation, all Bids must include the NFCC computation pursuant to Section 23.4.1.4 of the 2016 revised IRR of RA No. 9184, which must be sufficient for the total of the ABCs for all the lots or items participated in by the prospective Bidder. For bidders submitting the committed Line of Credit, it must be at least equal to ten percent (10%) of the ABCs for all the lots or items participated in by the prospective Bidder.

20. Post-Qualification

- 20.2. Within a non-extendible period of five (5) calendar days from receipt by the Bidder of the notice from the BAC that it submitted the Lowest Calculated Bid, the Bidder shall submit its latest income and business tax returns filed and paid through the BIR Electronic Filing and Payment System (eFPS) and other appropriate licenses and permits required by law and stated in the **BDS**.

21. Signing of the Contract

- 21.1. The documents required in Section 37.2 of the 2016 revised IRR of RA No. 9184 shall form part of the Contract. Additional Contract documents are indicated in the **BDS**.

III. Bid Data Sheet

Bid Data Sheet

ITB Clause	
5	<p>The following persons shall be eligible to participate in this bidding:</p> <ol style="list-style-type: none"> a. Duly licensed Filipino citizens/sole proprietorships; b. Partnerships duly organized under the laws of the Philippines and of which at least sixty percent (60%) of the interest belongs to citizens of the Philippines; c. Corporations duly organized under the laws of the Philippines and of which at least sixty percent (60%) of the of the outstanding capital stock belongs to citizens of the Philippines; d. Cooperatives duly organized under the laws of the Philippines and of which at least sixty percent (60%) of the interest belongs to citizens of the Philippines; e. Must be engaged in business for the supply, installation, operation, repair, and service maintenance of Inverter-type, DX-Type, Air Handling Units (AHUs) and Multi-Split Variable Refrigerant Volume (VRV)/Variable Refrigerant Flow (VRF), Inverter-Type, Packaged Air-conditioner centralized air conditioning system for the last three years (3) years; f. Must be an authorized distributor/dealer, installer and service contractor of Inverter-type, DX-Type, Air Handling Units (AHUs) and VRV/VRF multi-split, inverter-type packaged air conditioning system/units in the Philippines for the past three (3) years; g. Must have at least one (1) supply and installation and/or repair and maintenance project for Inverter-type, DX-Type, Air Handling Units (AHUs) and/or Multi-Split Variable Refrigerant Volume/Variable Refrigerant Flow (VRV/VRF) Inverter-Type Packaged Air-conditioners within the past three (3) years and having a total project cost of at least fifty percent (50%) of the ABC of the Project to be bid; and h. With no delayed project delivery/completion, or unsatisfactory project performance and/or after-sales service during warranty period at PICC for the past two (2) years.
5.3	<p>For this purpose, similar contract shall refer to installation, repair and maintenance of DX-Type, Packaged Air Handling Units and/or Multi-split Variable Refrigerant Volume/Variable Refrigerant Flow (VRV/VRF) Inverter-type Packaged Air-conditioners.</p> <p>The Bidder must have completed within the last three (3) years a single contract that is similar to this requirement, the amount of which shall be at least fifty percent (50%) of the ABC.</p>

7.1	Sub-contracting is not allowed
12	Not applicable
14.1	<p>The bid security shall be in the form of a Bid Securing Declaration, or any of the following forms and amounts:</p> <p>a. In the amount of not less than ₱101,000.00, or Cash, cashier's/manager's check, bank draft/guarantee or irrevocable letter of credit;</p> <p>b. Surety Bond in the amount of not less than ₱252,500.00.</p>
15	<p>Sealing and Marking of Bids</p> <p>Each Bidder shall submit the original and one (1) copy of the first and second components of its Bid. Technical and Financial documents must be placed in separate envelopes properly marked and sealed (see attached Illustrations)</p>
16.1	<p>The address for submission of bids is:</p> <p style="text-align: center;">PICC-Bids and Awards Committee (BAC) Secretariat Ground floor, Delegation Building PICC Complex, 1307 Pasay City</p> <p>The deadline for submission of bids is May 05, 2025 at 10:30 a.m.</p>
17.1	<p>The place of bid</p> <p style="text-align: center;">BAC CONFERENCE ROOM Function Room B, 2nd Floor, Secretariat Building PICC Complex, 1307 Pasay City</p> <p>The date and time of bid opening is May 05, 2025 at 11:00 a.m.</p> <p>In the event that the Bids cannot be opened as scheduled due to justifiable reasons, and in the absence of prior BAC activities, the BAC will take custody of the submitted Bids, with the opening deferred to the next working day at the same time and venue. The BAC will issue a formal Notice to Bidders by posting it on the BAC Secretariat/Procurement Unit electronic bulletin board and the PICC website, providing the revised schedule..</p>
19.3	<p>The Total ABC is FIVE MILLION FIFTY THOUSAND PESOS (PhP5,050,000.00), VAT Inclusive.</p>

46

20.2	<p>Within a non-extendible period of five (5) calendar days from receipt by the bidder of the notice from the BAC that it submitted the LCB, the Bidder shall submit the following documentary requirements:</p> <ul style="list-style-type: none"> a. Certified Photocopy of the CY 2024 Income and Business Tax Returns with proof of payment; b. Valid Tax Clearance; c. Sections III and V of the bid documents, signed on each and every page by the bidder's authorized representative; d. Company Profile with statements that they have an established office/shop equipment and personnel (with sketch of office location); e. Certificate of authorized distributorship and service contractor for at least three (3) years signed by equipment manufacturer or by exclusive/main distributor in the case of sub-dealer/distributor. f. Certification from manufacturer that the equipment to be installed is compliant to environmental Directive for Restriction of Hazardous Substances (RoHS) both for electrical and electronic equipment and devices. Such certification shall be treated as compliant to RA 6969/DENR Administrative Order No. 2005-05 (Toxic Chemical Substances for Issuance of Chemical Control Orders); g. Warranty Certificate for Compressors covering a five-year period h. Certification from PICC' Mechanical Services Division that the participating bidder has conducted ocular inspection of the room location of cooling and panel boards, source of power supply and vicinity; i. Three (3) sets Installation plan and drawing using 30" by 40" size drawing sheet format – 1 set tracing paper and 2 sets blue prints; j. Three (3) sets Electrical Layout (single-line)/drawing using 30" by 40" size drawing sheet format – 1 set tracing paper and 2 sets blue prints; and k. Certificate of satisfactory Completion & Acceptance of Previous PICC or BSP Projects undertaken within the last two (2) years, if any.
21.2	No additional requirement

Section IV. General Conditions of Contract

1. Scope of Contract

This Contract shall include all such items, although not specifically mentioned, that can be reasonably inferred as being required for its completion as if such items were expressly mentioned herein. All the provisions of RA No. 9184 and its 2016 revised IRR, including the Generic Procurement Manual, and associated issuances, constitute the primary source for the terms and conditions of the Contract, and thus, applicable in contract implementation. Herein clauses shall serve as the secondary source for the terms and conditions of the Contract.

This is without prejudice to Sections 74.1 and 74.2 of the 2016 revised IRR of RA No. 9184 allowing the GPPB to amend the IRR, which shall be applied to all procurement activities, the advertisement, posting, or invitation of which were issued after the effectivity of the said amendment.

Additional requirements for the completion of this Contract shall be provided in the **Special Conditions of Contract (SCC)**.

2. Advance Payment and Terms of Payment

- 2.1. Advance payment of the contract amount is provided under Annex "D" of the revised 2016 IRR of RA No. 9184.
- 2.2. The Procuring Entity is allowed to determine the terms of payment on the partial or staggered delivery of the Goods procured, provided such partial payment shall correspond to the value of the goods delivered and accepted in accordance with prevailing accounting and auditing rules and regulations. The terms of payment are indicated in the **SCC**.

3. Performance Security

Within ten (10) calendar days from receipt of the Notice of Award by the Bidder from the Procuring Entity but in no case later than prior to the signing of the Contract by both parties, the successful Bidder shall furnish the performance security in any of the forms prescribed in Section 39 of the 2016 revised IRR of RA No. 9184

4. Inspection and Tests

The Procuring Entity or its representative shall have the right to inspect and/or to test the Goods to confirm their conformity to the Project *{[Include if Framework Agreement will be used:] or Framework Agreement}* specifications at no extra cost to the Procuring Entity in accordance with the Generic Procurement Manual. In addition to tests in the **SCC, Section IV (Technical Specifications)** shall specify what inspections and/or tests the Procuring Entity requires, and where they are to be conducted. The Procuring Entity shall notify the Supplier in writing, in a timely manner, of the identity of any representatives retained for these purposes.

All reasonable facilities and assistance for the inspection and testing of Goods, including access to drawings and production data, shall be provided by the Supplier to the authorized inspectors at no charge to the Procuring Entity.

5. Warranty

5.1 In order to assure that manufacturing defects shall be corrected by the Supplier, a warranty shall be required from the Supplier as provided under Section 62.1 of the 2016 revised IRR of RA No. 9184.

5.2 The Procuring Entity shall promptly notify the Supplier in writing of any claims arising under this warranty. Upon receipt of such notice, the Supplier shall, repair or replace the defective Goods or parts thereof without cost to the Procuring Entity, pursuant to the Generic Procurement Manual.

6. Liability of the Supplier

The Supplier's liability under this Contract shall be as provided by the laws of the Republic of the Philippines.

If the Supplier is a joint venture, all partners to the joint venture shall be jointly and severally liable to the Procuring Entity.

Section V. Special Conditions of Contract

Special Conditions of Contract

GCC Clause	
1	The Procuring Entity is <i>The Philippine International Convention Center (PICC)</i>
2.2	<p>Payment</p> <p>Payment shall be released in full within 3 to 4 weeks after final acceptance by PICC or its representative of the Contractor's completed work, and submission of billing and complete supporting documents by Contractor as follows:</p> <ol style="list-style-type: none"> 1.) Equipment delivery receipts, and Certificate of Completion/Turn-over Report. 2.) Invoice. 3.) Copy of delivery receipts of spare parts on drain pumps, indoor printed circuit boards and outdoor printed circuit boards. 4.) Copy of delivery receipt for the return of replaced parts/materials, if any 5.) Two (2) sets of Equipment manuals as follows: <ol style="list-style-type: none"> 5.1. design manual, 5.2. installation manual, 5.3. operation and maintenance manual. 6.) Design software for specific load/capacity calculation of the units to be installed. 7.) Three (3) sets Detailed As-built installation plans and three (3) sets electrical layout. One of the three (3) sets of each plan is the original drawing using tracing paper, 30"x40" sheet format. 8.) Original copy of Certification from manufacturer that the equipment/electrical and electronic components are compliant to Directive for Restriction of Hazardous Substance both for electrical and electronic equipment and devices. 9.) Original Notarized copy of Five (5)-Year Warranty Certificate for all compressors supplied. 10.) Equipment/System Operation and Commissioning Test Data Report for each indoor and outdoor equipment as required under Conditions Item No. 9 11.) Photocopy of Training Certificate issued by the Contractor. 12.) Contractor's Recommendation for: <ol style="list-style-type: none"> a. Proper maintenance forms for observations, monitoring and recording operational data and trouble. b. Proper periodic maintenance check-up activities and standard operating procedures on daily, weekly, monthly, quarterly and annual basis.

H

	<p>Failure to submit bank guarantee certificate shall mean deduction of ten percent (10%) retention money as guarantee obligation for one (1) year warranty period.</p>								
3	<p>Performance Security</p> <p>Within ten (10) calendar days from receipt of the Notice of Award, but in no case later than the signing of the contract by both parties, the successful Bidder shall furnish the performance security in any of the following forms:</p> <table border="1"> <thead> <tr> <th>Form of Performance Security</th> <th>Amount of Performance Security (Equal to Percentage of the Total Contract Price)</th> </tr> </thead> <tbody> <tr> <td>Cash or Cashier's/Manager's Check issued by a Universal or Commercial Bank.</td> <td>Five percent (5%)</td> </tr> <tr> <td>Bank draft/guarantee issued by a Universal or Commercial Bank</td> <td>Five percent (5%)</td> </tr> <tr> <td>Surety bond callable upon demand issued by a surety or insurance company duly certified by the Insurance Commission as authorized to issue such security.</td> <td>Thirty percent (30%)</td> </tr> </tbody> </table>	Form of Performance Security	Amount of Performance Security (Equal to Percentage of the Total Contract Price)	Cash or Cashier's/Manager's Check issued by a Universal or Commercial Bank.	Five percent (5%)	Bank draft/guarantee issued by a Universal or Commercial Bank	Five percent (5%)	Surety bond callable upon demand issued by a surety or insurance company duly certified by the Insurance Commission as authorized to issue such security.	Thirty percent (30%)
Form of Performance Security	Amount of Performance Security (Equal to Percentage of the Total Contract Price)								
Cash or Cashier's/Manager's Check issued by a Universal or Commercial Bank.	Five percent (5%)								
Bank draft/guarantee issued by a Universal or Commercial Bank	Five percent (5%)								
Surety bond callable upon demand issued by a surety or insurance company duly certified by the Insurance Commission as authorized to issue such security.	Thirty percent (30%)								
4	<p>Inspection and Tests</p> <p>PICC may reject any works and materials that do not conform to the scope of works. The Contractor shall rectify such rejected work/s to meet the standard set in the scope of works Section VII – Technical Specifications at no cost to PICC.</p>								
5	<p>Warranty</p> <p>The Air Conditioning Units shall be covered by:</p> <ol style="list-style-type: none"> 1. One (1) year warranty on parts and labor. 2. Five (5) years warranty on compressor. <p>Said warranties shall include travel time and expense and provision of on-site service and labor.</p> <p>The obligation for the warranty shall be covered by, at the Contractor's option, either retention money or an amount equivalent to ten percent (10%) of the Contract amount, or a bank guarantee certificate equivalent to ten percent (10%) of the total Contract amount (see details under payment). However, bank guarantee certificate shall not be accepted as substitute for ten percent (10%) retention money for progress billing except for the final payment stage. Note</p>								

	<p>that PICC at its option may deduct retention money equivalent to ten percent (10%) for every progress billing/payment. Said warranty obligation shall be released only after the expiration of general warranty period of one (1) year, however, the same will be forfeited by PICC as part of payment for any damage of supplied equipment and surrounding equipment components/parts attributable to contractor's negligence or poor workmanship during the installation and/or test operation period.</p> <p>As part of the one-year general warranty, the contractor must conduct monthly check-up and servicing of the indoor and outdoor units with proper service records and reports for submission to PICC-Mechanical Services Division.</p>
6	<p>The period for correction of defects is seven (7) calendar days upon receipt of notice from PICC project-in-charge.</p>

Section VI. Schedule of Requirements

The delivery schedule expressed as weeks/months stipulates hereafter a delivery date which is the date of delivery to the project site.

Item Number	Description	
I	Supply and Installation of One (1) 50-TR Direct Expansion Type Packaged Air Handling Unit as Replacement of the Old/Existing Unit Serving Meeting Room 1	Completion shall be within One Hundred Eighty (180) Calendar Days after receipt of Notice to Proceed.

I hereby commit to comply and deliver all the above requirements in accordance with the above stated schedule.

Name of Company / Bidder

Signature over printed Name of Authorized Representative

Position

Date

Section VII. Technical Specifications

**(REFER TO THE PICC TECHNICAL
SPECIFICATIONS)**

Section VIII. Checklist of Technical and Financial Documents

Checklist of Technical and Financial Documents

I. TECHNICAL COMPONENT ENVELOPE

Class "A" Documents

Legal Documents

- (a) Valid PhilGEPS Registration Certificate (Platinum Membership) (all pages) **in accordance with Section 8.5.2 of the IRR. If any of the documents in Annex "A" are expired, the updated document shall be submitted during post-qualification;**

Technical Documents

- (b) Statement of the prospective bidder of all its ongoing government and private contracts, including contracts awarded but not yet started, if any, whether similar or not similar in nature and complexity to the contract to be bid (**Annex "A"**); **and**
- (c) Statement of the bidder's Single Largest Completed Contract (SLCC) similar to the contract to be bid, except under conditions provided for in Sections 23.4.1.3 and 23.4.2.4 of the 2016 revised IRR of RA No. 9184, within the relevant period as provided in the Bidding Documents (**Section "B"**); **and**
- (d) Original copy of Bid Security. If in the form of a Surety Bond, submit also a certification issued by the Insurance Commission or Original copy of Notarized Bid Securing Declaration (**Annex C"**); **and**
- (e) Conformity with the Technical Specifications (**Section VII**-signed on each and every page), which includes production/delivery schedule, manpower requirements, and/or after-sales/parts (**Section VI**), if applicable; **and**
- (f) Original duly signed Omnibus Sworn Statement (OSS) **and** if applicable, Original Notarized Secretary's Certificate in case of a corporation, partnership, or cooperative; or Original Special Power of Attorney of all members of the joint venture giving full power and authority to its officer to sign the OSS and do acts to represent the Bidder (**Annex "D"**).

Financial Documents

- (g) The prospective bidder's computation of Net Financial Contracting Capacity (NFCC) (**Annex "E"**) or A committed Line of Credit from a Universal or Commercial Bank in lieu of its NFCC computation.

Class "B" Documents

- (h) If applicable, a duly signed joint venture agreement (JVA) in case the joint venture is already in existence or duly notarized statements from all the potential joint venture partners stating that they will enter into and abide by the provisions of the JVA in the instance that the bid is successful.

II. FINANCIAL COMPONENT ENVELOPE

- (i) Original of duly signed and accomplished Financial Bid Form;

Other documentary requirements under RA No. 9184

- (a) Original of duly signed Bid Prices in the Bill of Quantities (**Section VIII**)

Bid Securing Declaration Form

[shall be submitted with the Bid if bidder opts to provide this form of bid security]

REPUBLIC OF THE PHILIPPINES)
CITY OF _____) S.S.

BID SECURING DECLARATION
Project Identification No.: *[Insert number]*

To: *[Insert name and address of the Procuring Entity]*

I/We, the undersigned, declare that:

1. I/We understand that, according to your conditions, bids must be supported by a Bid Security, which may be in the form of a Bid Securing Declaration.
2. I/We accept that: (a) I/we will be automatically disqualified from bidding for any procurement contract with any procuring entity for a period of two (2) years upon receipt of your Blacklisting Order; and, (b) I/we will pay the applicable fine provided under Section 6 of the Guidelines on the Use of Bid Securing Declaration, within fifteen (15) days from receipt of the written demand by the procuring entity for the commission of acts resulting to the enforcement of the bid securing declaration under Sections 23.1(b), 34.2, 40.1 and 69.1, except 69.1(f), of the IRR of RA No. 9184; without prejudice to other legal action the government may undertake.
3. I/We understand that this Bid Securing Declaration shall cease to be valid on the following circumstances:
 - a. Upon expiration of the bid validity period, or any extension thereof pursuant to your request;
 - b. I am/we are declared ineligible or post-disqualified upon receipt of your notice to such effect, and (i) I/we failed to timely file a request for reconsideration or (ii) I/we filed a waiver to avail of said right; and
 - c. I am/we are declared the bidder with the Lowest Calculated Responsive Bid, and I/we have furnished the performance security and signed the Contract.

IN WITNESS WHEREOF, I/We have hereunto set my/our hand/s this ____ day of *[month]* *[year]* at *[place of execution]*.

[Insert NAME OF BIDDER OR ITS AUTHORIZED REPRESENTATIVE]

[Insert signatory's legal capacity]

Affiant

SUBSCRIBED AND SWORN to before me this ____ day of *[month]* *[year]* at *[place of execution]*, Philippines. Affiant/s is/are personally known to me and was/were identified by me through competent evidence of identity as defined in the 2004 Rules on Notarial Practice (A.M. No. 02-8-13-SC). Affiant/s exhibited to me his/her *[insert type of government*

identification card used], with his/her photograph and signature appearing thereon, with no. _____ and his/her Community Tax Certificate No. _____ issued on ____ at _____.

Witness my hand and seal this ____ day of *[month]* *[year]*.

NAME OF NOTARY PUBLIC

Serial No. of Commission _____

Notary Public for _____ until _____

Roll of Attorneys No. _____

PTR No. _____ *[date issued]*, *[place issued]*

IBP No. _____ *[date issued]*, *[place issued]*

Doc. No. _____

Page No. _____

Book No. _____

Series of _____

Omnibus Sworn Statement (Revised)

[shall be submitted with the Bid]

REPUBLIC OF THE PHILIPPINES)
CITY/MUNICIPALITY OF _____) S.S.

AFFIDAVIT

I, [Name of Affiant], of legal age, [Civil Status], [Nationality], and residing at [Address of Affiant], after having been duly sworn in accordance with law, do hereby depose and state that:

1. *[Select one, delete the other:]*

[If a sole proprietorship:] I am the sole proprietor or authorized representative of [Name of Bidder] with office address at [address of Bidder];

[If a partnership, corporation, cooperative, or joint venture:] I am the duly authorized and designated representative of [Name of Bidder] with office address at [address of Bidder];

2. *[Select one, delete the other:]*

[If a sole proprietorship:] As the owner and sole proprietor, or authorized representative of [Name of Bidder], I have full power and authority to do, execute and perform any and all acts necessary to participate, submit the bid, and to sign and execute the ensuing contract for [Name of the Project] of the [Name of the Procuring Entity], as shown in the attached duly notarized Special Power of Attorney;

[If a partnership, corporation, cooperative, or joint venture:] I am granted full power and authority to do, execute and perform any and all acts necessary to participate, submit the bid, and to sign and execute the ensuing contract for [Name of the Project] of the [Name of the Procuring Entity], as shown in the attached [state title of attached document showing proof of authorization (e.g., duly notarized Secretary's Certificate, Board/Partnership Resolution, or Special Power of Attorney, whichever is applicable)];

3. [Name of Bidder] is not "blacklisted" or barred from bidding by the Government of the Philippines or any of its agencies, offices, corporations, or Local Government Units, foreign government/foreign or international financing institution whose blacklisting rules have been recognized by the Government Procurement Policy Board, **by itself or by relation, membership, association, affiliation, or controlling interest with another blacklisted person or entity as defined and provided for in the Uniform Guidelines on Blacklisting;**

4. Each of the documents submitted in satisfaction of the bidding requirements is an authentic copy of the original, complete, and all statements and information provided therein are true and correct;

5. [Name of Bidder] is authorizing the Head of the Procuring Entity or its duly authorized representative(s) to verify all the documents submitted;

6. *[Select one, delete the rest:]*

[If a sole proprietorship:] The owner or sole proprietor is not related to the Head of the Procuring Entity, Procurement Agent if engaged, members of the Bids and Awards

Committee (BAC), the Technical Working Group, and the BAC Secretariat, the head of the Project Management Office or the end-user unit, and the project consultants by consanguinity or affinity up to the third civil degree;

[If a partnership or cooperative:] None of the officers and members of *[Name of Bidder]* is related to the Head of the Procuring Entity, Procurement Agent if engaged, members of the Bids and Awards Committee (BAC), the Technical Working Group, and the BAC Secretariat, the head of the Project Management Office or the end-user unit, and the project consultants by consanguinity or affinity up to the third civil degree;

[If a corporation or joint venture:] None of the officers, directors, and controlling stockholders of *[Name of Bidder]* is related to the Head of the Procuring Entity, Procurement Agent if engaged, members of the Bids and Awards Committee (BAC), the Technical Working Group, and the BAC Secretariat, the head of the Project Management Office or the end-user unit, and the project consultants by consanguinity or affinity up to the third civil degree;

7. *[Name of Bidder]* complies with existing labor laws and standards; and
8. *[Name of Bidder]* is aware of and has undertaken the responsibilities as a Bidder in compliance with the Philippine Bidding Documents, which includes:
 - a. Carefully examining all of the Bidding Documents;
 - b. Acknowledging all conditions, local or otherwise, affecting the implementation of the Contract;
 - c. Making an estimate of the facilities available and needed for the contract to be bid, if any; and
 - d. Inquiring or securing Supplemental/Bid Bulletin(s) issued for the *[Name of the Project]*.
9. *[Name of Bidder]* did not give or pay directly or indirectly, any commission, amount, fee, or any form of consideration, pecuniary or otherwise, to any person or official, personnel or representative of the government in relation to any procurement project or activity.
10. **In case advance payment was made or given, failure to perform or deliver any of the obligations and undertakings in the contract shall be sufficient grounds to constitute criminal liability for Swindling (Estafa) or the commission of fraud with unfaithfulness or abuse of confidence through misappropriating or converting any payment received by a person or entity under an obligation involving the duty to deliver certain goods or services, to the prejudice of the public and the government of the Philippines pursuant to Article 315 of Act No. 3815 s. 1930, as amended, or the Revised Penal Code.**

IN WITNESS WHEREOF, I have hereunto set my hand this ___ day of ___, 20__ at _____, Philippines.

[Insert NAME OF BIDDER OR ITS AUTHORIZED REPRESENTATIVE]

[Insert signatory's legal capacity]

Affiant

SUBSCRIBED AND SWORN to before me this ___ day of *[month]* *[year]* at *[place of execution]*, Philippines. Affiant/s is/are personally known to me and was/were identified by

me through competent evidence of identity as defined in the 2004 Rules on Notarial Practice (A.M. No. 02-8-13-SC). Affiant/s exhibited to me his/her [insert type of government identification card used], with his/her photograph and signature appearing thereon, with no. _____ and his/her Community Tax Certificate No. _____ issued on ____ at _____.

Witness my hand and seal this ____ day of *[month]* *[year]*.

NAME OF NOTARY PUBLIC

Serial No. of Commission _____

Notary Public for _____ until _____

Roll of Attorneys No. _____

PTR No. _____ *[date issued], [place issued]*

IBP No. _____ *[date issued], [place issued]*

Doc. No. _____

Page No. _____

Book No. _____

Series of _____

PHILIPPINE INTERNATIONAL CONVENTION CENTER

Name of the Project: **Supply and Installation of One (1) 50-TR Direct Expansion-Type Packaged Air Handling Unit as Replacement of the Old/Existing Unit Serving Meeting Room 1**

FINANCIAL DOCUMENTS FOR ELIGIBILITY CHECK

A. Summary of the Applicant Supplier's/Distributor's/Manufacturer's assets and liabilities on the basis of the attached Income Tax Return and Audited Financial Statement, stamped "RECEIVED" by the Bureau of Internal Revenue or BIR authorized collecting agent, for the immediately preceding year and a certified copy of Schedule of Fixed Assets particularly the list of construction equipment.

		Year 20
1.	Total Assets	
2.	Current Assets	
3.	Total Liabilities	
4.	Current Liabilities	
5.	Net Worth (1-3)	
6.	Net Working Capital (2-4)	
7.	Value of all outstanding or uncompleted portions of the project under ongoing contracts, including awarded contracts yet to be started coinciding with contract to be bid.	

B. The Net Financial Contracting Capacity (NFCC) based on the above data is computed as follows:

NFCC = [(Current assets minus current liabilities) (15)] minus value of all outstanding or uncompleted portions of the project under ongoing contracts, including awarded contracts yet to be started coinciding with contract to be bid.

NFCC = P _____

The values of the bidder's current assets and current liabilities shall be based on the data submitted to the BIR.

or

A committed Line of Credit, in an amount to at least ten percent (10%) of the ABC, issued by a Universal of Commercial Bank.

Submitted by:

Name of Supplier / Distributor / Manufacturer

Signature of Authorized Representative

Date: _____

Note:

1. If Partnership or Joint Venture, each Partner or Member Firm of Joint Venture shall submit the above requirements.

BID FORM

Date: _____

Project Identification No.: _____

To: *[name and address of Procuring Entity]*

Having examined the Philippine Bidding Documents (PBDs) including the Supplemental or Bid Bulletin Numbers *[insert numbers]*, the receipt of which is hereby duly acknowledged, we, the undersigned, offer to **Supply and Installation of One (1) 50-TR Direct Expansion Type Packaged Air Handling Unit as Replacement of the Old/Existing Unit Serving Meeting Room 1** the sum of:

TOTAL CONTRACT RATE: INCLUSIVE OF VALUE ADDED TAX (VAT)

(Amount in Words) (P _____) (Amount in figures)

or the total calculated bid price, as evaluated and corrected for computational errors, and other bid modifications in accordance with the Price Schedules attached herewith and made part of this Bid. The total bid price includes the cost of all taxes, such as, but not limited to: *[specify the applicable taxes, e.g. (i) value added tax (VAT), (ii) income tax, (iii) local taxes, and (iv) other fiscal levies and duties]*, which are itemized herein or in the Price Schedules (see attached),

If our Bid is accepted, we undertake:

- a. to deliver the services in accordance with the schedule specified in the Schedule of Requirements of the Philippine Bidding Documents (PBDs);
- b. to provide a performance security in the form, amounts, and within the times prescribed in the PBDs;
- c. to abide by the Bid Validity Period specified in the PBDs and it shall remain binding upon us at any time before the expiration of that period.

Until a formal Contract is prepared and executed, this Bid, together with your written acceptance thereof and your Notice of Award, shall be binding upon us.

We understand that you are not bound to accept the Lowest Calculated Bid or any Bid you may receive.

We certify/confirm that we comply with the eligibility requirements pursuant to the PBDs.

The undersigned is authorized to submit the bid on behalf of *[name of the bidder]* as evidenced by the attached *[state the written authority]*.

Name: _____

Legal capacity: _____

Signature: _____

Duly authorized to sign the Bid for and behalf of: _____

Date: _____



TECHNICAL SERVICES DEPARTMENT

MECHANICAL DIVISION

Technical Specifications for the Supply and Installation of One (1) 50-TR Direct Expansion Type Packaged Air Handling Unit as Replacement of the Old/Existing Unit Serving Meeting Room 1

APP No.: PICC APP2025-MC-52

Date: April 03, 2025

End-User :

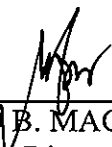

MARIO B. MACANAS
Assistant Director, TSD-MSD

Technical Specifications

Item	Specification	Statement of Compliance
<p>I. SUPPLY AND INSTALLATION OF ONE (1) 50-TR DIRECT EXPANSION-TYPE PACKAGED AIR HANDLING UNIT AS REPLACEMENT OF THE OLD/EXISTING UNIT SERVING MEETING ROOM 1.</p> <p>II. SCOPE OF WORKS:</p> <p>Supply, delivery and installation of Inverter - Direct Expansion Type Package Air Handling Unit, with a minimum requirement of design, engineering, fabrication, assembly fabrication, air balancing, duct connection, testing and commissioning, and make the equipment operational.</p> <p>Contractor shall guarantee that the installation of new equipment shall fit/adopt to the existing Air Distribution System at Meeting Room 1 and as a fitting replacement for the room's existing air-conditioning system in terms of efficiency cooling capacity and noise level. All works herewith shall include but not limited to the following:</p> <p>1.1 One (1) unit – 50TR Cooling Capacity, Air Handling Unit (AHU), DX-type Heat Exchanger, interwinded design based on coil section with even distribution of refrigerant using environment-friendly refrigerant R-410A or R32. Double Inlet, Backward Curved/Forward Curved, Multi-Vane Impeller, Centrifugal Blowers having non-overloading characteristics, equipped with stainless metal mechanical adjuster, 17,500-24,000cfm, 440-480 Volts, 3 Phase, 60Hz, built-in variable speed drive (VSD) fan motor controller, with stand-by heavy-duty Variable Frequency Drive (VFD) IEC Standards, equipped with a bypass starter control, Direct on Line Starter or Wye Delta Starter, in National Electrical Manufacturers Association (NEMA) 1 enclosure. With very low or low noise/sound level – shall not exceed the existing AHU's noise/sound level (50-56dBA). AHU Housing shall be double wall insulated AHU casing. Exposed insulation is not accepted. Panel insulation shall be a non-hazardous element complying with the requirements of NFPA 90A that is resistant to mold growth in accordance with a standardized test method such as UL 181 or ASTM C 1338. Panel Assembly shall meet UL standards 1995 for fire safety with a minimum thickness of Gauge #18, GI material coated with oven-baked finish.</p> <p>1.2 One (1) lot – Modular Air Cooled Condensing Units (ACCUs) with cooling capacity appropriately-designed by participating contractor for the total capacity of above indoor units per cluster and with extra/stand-by modular unit, modular-type, 440-460 Volts, 3 phase, 60 Hz using environment-friendly refrigerant R410A or R32 and electronics/electrical parts compliant with the Directive for restriction of</p>		

hazardous substance (RoHS), equipped with inverter-inverter combination of compressors or master/lead (1 inverter) and slave scroll compressors, equipped with automatic by-pass compressor operation system control – meaning, the air conditioning system operation shall continue even if one or two compressors break down, complete of necessary control devices, sensors, shut-off valves, piping, piping kits, and accessories for complete and normal operating condition with the indoor unit. Compressor (inverter and/or slave) should be available in the local market. Outdoor unit shall operate at maximum 48°C ambient operational condition. If the outdoor unit is 380V or 220-230V, the Contractor shall provide a step-down transformer.

Note: PICC shall provide 440-480Volts power supply for DX-type AHU Equipment Installation

- 1.2.1 Inverter lead and inverter combination of compressor system or a master/lead (1 inverter) and slave scroll compressors system.
- 1.2.2. Installation design and operational capacity combination ratio of AHU/indoor and outdoor units shall never be more than 10 percent or the total rated capacity of outdoor unit shall never be less than 90 percent of the total rated capacity of combination of indoor unit capacity. In addition, the outdoor system must be able to operate properly at 50 percent capacity or when the indoor units' capacity is reduced to 50 percent.
- 1.2.3. High system efficiency or coefficient of performance (COP) or the ratio of the cooling (capacity) provided over the electrical energy consumed ranging from 1.2219 (16HP) to 0.8617(50HP) or up to 0.8553 (54HP).
- 1.2.4. Compliant with the low sound level requirements as follows:
 - 1.2.4.1. AHU/Indoor unit – the specified sound level for each type and model for low, medium and high speed fan shall be the basis and strictly followed (refer to individual unit's specification as required in this bidding document).
 - 1.2.4.2. Modular outdoor unit - 45 to 68 dB(A)
- 1.2.5. Automatic back up operation for multiple outdoor and/or single outdoor unit – meaning, the entire system continues to operate automatically even if one or more compressor or outdoor units break down. The air conditioning system should continue to operate

automatically with the remaining non-defective compressor or outdoor units.

- 1.2.6. Capacity increment of modular outdoor unit must be limited to 2Hp up to 8Hp.
- 1.2.7. Compliant with both (1.) environment-friendly refrigerant and (2.) directive for restriction of hazardous substance (RoHS) both for electrical and electronic equipment and devices. It is an international environment directive to regulate the use of designated chemical substances such as: lead, cadmium, hexavalent chromium, mercury, polybrominated biphenyls and polybrominated diphenylether in electronic and electrical equipment which is also in compliance with Republic Act (RA) 6969 known as the Toxic Substances and Hazardous and Nuclear Waste Control Act of 1990.
- 1.2.8. Equipped with automatic test operation for system check and trouble shooting.
- 1.2.9. Currently certified aircon units or product by AHRI (Air-Conditioning, Heating, and Refrigeration Institute).
- 1.2.10. With controllers for zoning, interlocking of equipment and ready and compatible with building management system (BMS) connection.
- 1.2.11. Easy wiring for normal centralized address setting.

- 1.3. One (1) lot Outdoor Unit printed circuit board (OU-PCB). One (1) extra or spare of complete set of PCB must be provided/delivered for each model of PCB installed in each different outdoor door unit.
- 1.4. One (1) lot Branch piping header/joints or ref-net joints and other devices and accessories necessary for complete installation and accessories.
- 1.5. One (1) lot AHU kit controller / EEV kit controller. One (1) extra or spare of complete set of AHU kit controller / EEV kit controller must be provided/delivered for each model of PCB installed in each different AHU kit controller / EEV kit controller.
- 1.6. One (1) lot Watt-hour meter, digital, 3 phase 3 wires, CT rated, 230 volts, with RS232 communication connection, panel mounted; complete with the required current transformers, compatible with building management system (BMS) connection for the proper monitoring

	of the total power consumption of the air-conditioning units/system to be installed. Provide and install one (1) unit for the main feeder line if the power of all indoor units and outdoor units is sourced/connected directly from one (1) power supply system.
1.7. One (1) lot	Hard-drawn copper tubes (type L), PVC condensate drain pipe and fittings, clamps, supports and other materials necessary for the proper and complete installation of the above units.
1.8. One (1) lot	Close-cell rubber insulation (Aeroflex or its approved equivalent), one (1)-inch thick or its approved equivalent.
1.9. One (1) lot	Electrical wires – Thermoplastic High Heat Nylon (THHN) for main supply cables, feeder lines and control lines, steel conduits/IMC panel boards/enclosure – weather-proof, System outdoor and indoor unit main circuit breakers and sub-breakers - Square D, G.E. or approved equivalent, magnetic starter with overload relay- Fujihaya or approved equivalent, controllers, and accessories for the power supply and control system of the above air conditioners. Each indoor unit shall be provided with circuit breaker for control and isolation purposes for safety and repair works.
1.10. One (1) lot	Environment-friendly system refrigerant R410A or R32.
1.11. One (1) lot	Environment-friendly cleaning agent, R-141B for flushing.
1.12. One (1) lot	Nitrogen gas for flushing and cleaning the pipe line.
1.13. One (1) lot	Oxygen-acetylene gas for cutting and welding works.
1.14. One (1) lot	Silver rods and other miscellaneous materials and supplies.
1.15. One (1) lot	Angle bars, 3/16” thick for steel base of fan coil units, 1/8” thick for supports. Use only engineering standard thickness (no commercial standard)
1.16. One (1) lot	Epoxy primer, enamel paints and other parts and materials necessary for the completion of repair works.
1.17. One (1) lot	Duct and other related ductworks, including additional air duct stiffener as needed. Ductwork shall be constructed of G90 galvanized steel sheet

Hy

with 25mm polyolefin insulation with aluminum foil vapor barrier on one side. Semi-Rigid Flexible Duct shall be use for duct to diffuser/grille connections.

G.I. Sheet Duct:

#26 = 300mm

#24 = 325 to 750mm

#22 = 775 to 1,350mm

#20 = 1,375 to 2,100mm

#18 = above 2,100mm

1.18. One (1) lot Miscellaneous materials and accessories necessary for the completion of works and other restoration works such as roof deck water proofing restoration.

1.19. One (1) lot Materials for cementitious water proofing works for AHU Room

2.0. Dismantle the existing Packaged Air Handling Unit (PAHU) to be replaced with DX-type Air Handling Unit serving Meeting Room 1 including all accessories and turn over the said equipment and accessories to PICC-MSD Assistant Director or his authorized representative. Disassemble with care the existing AHU from the existing supply/return ducts. Be careful not to damage the existing supply/return ducts. Re-integration/connection of the new 50TR PAHU to the existing air duct/s must be properly designed for a rigid, efficient and silent operation of the system.

2.1. Ensure that the Power Supply and Control Devices are all disconnected prior to any dismantling activity.

2.2. Close Condenser Water Isolation Valve before disconnecting the pipe lines from the PAHU and install blind flanged after the disconnection activity.

2.3. Pump down the system's refrigerant and contain it in an appropriate refrigerant tank.

2.3. Demount Drive Motor Compressor from the PAHU and turn over to the MSD Assistant Director or his authorized representative.

2.4. Dismantle AHU, AHU housing, frames, air filters, chilled water pipe lines, cooling coils, and other accessories. Preserve integrity usability of dismantled mechanical equipment/electrical controls accessories.

2.5. Haul all waste/scrap materials from the area to the PICC's designated temporary storage at the vicinity of PICC Warehouse Building.

3.0. Air Distribution System - Use existing air duct distribution system. Isolate existing AHU equipment from the existing duct. Connect new DX-type, Air Handling Unit to the said existing duct with new neoprene 0.8mm thick flexible connectors with finished fabric width not less than 150mm. Flexible connectors shall have the same fire/temperature rating as the connecting ductwork. Install new Duct Header/Bell Mouth Duct with internal acoustic duct linings designed by the Contractor to minimize noise transmission and to avoid noise generation from the new AHU to the existing air duct distribution system. Ductworks after the Duct Header/Bell Mouth Duct shall have internal acoustic duct linings of at least 1.5m (5ft). Duct fabrication and installation

shall be in accordance with Sheet Metal and Air Conditioning Contractors' National Association (SMACNA) standards.

- 4.0. Design properly and appropriately the capacity of each set of inverter, DX-type AHUs based on the general design capacity and equipment schedule below and modular-type outdoor unit/s considering the capacity, type, and number of indoor units to be installed per set.

Note:

Consider the maximum power and comfort cooling efficiency of the system at summer (April-May) condition in the proper design capacity and selection of the modular outdoor unit. Occupied room temperature shall be within 73 – 74 degrees Fahrenheit during summer (April-May) condition when outdoor/dry-bulb temperature reaches 97 to 100 degrees Fahrenheit. Total capacity of outdoor unit/system shall never be less than 90 percent the total capacity of the entire AHU/indoor rated capacity or the total capacity of AHU/indoor unit shall never be more than 110 percent of the capacity of the outdoor unit even if the capability and capacity is up to 130 percent.

Table A-1: General Equipment Design Capacity and Distribution Plan (Schedule of Equipment)

Item No.	Area/	Area in Sq. M.	Detailed Specifications (Quantity, Capacity, Type of Units, Sound Level (dBA), etc...)
1	Meeting Room 1	() Specific area 1,419 m ² (total area)	1 unit – 50TR Inverter-type, DX-Type, Air Handling Units, other features (enumerate in details as required)

Note: Attached is the Floor Plan (size-long bond paper)

5. Make and submit a more detailed Equipment Design Capacity and Distribution Plan or Schedule of Equipment (long bond paper size only) for each room or area listing and showing the following:
- 5.1. Quantity, type and model of each indoor unit serving the room or area,
 - 5.2. Cooling capacity of each indoor unit in kilowatt (kW) and the equivalent tonnage (1 ton equals 12,000 BTU per Hour) and horsepower cooling capacity rating
 - 5.3. Airflow rate/capacity of each indoor unit in cubic meter per second (CMS) and in equivalent cubic feet per minute (CFM).
 - 5.4. Sound level pressure of each type/model of AHU/indoor unit in decibels A-weighting (dBA) indicating/showing the sound level for the low fan speed, medium fan speed and high fan speed for 3-speed units or low fan speed and high fan speed for 2-speed

units or low fan speed, 2 medium fan speeds and high fan speed for 4-speed units.

- 5.5. Total capacity of each room or area based on the designed and rated capacity of each equipment to be installed in kilowatt (kW) and the equivalent tonnage (1 ton equals 12, 000 BTU per Hour) and horsepower cooling capacity rating.
- 5.6. Power consumption or power input in kilowatt (kW)
- 5.7. Power supply indicating the voltage, full-load ampere, phase & frequency
- 5.8. Dimension – height, width and depth – in millimeter (mm) and weight in Kilogram
- 5.9. Colour of indoor unit, and
- 5.10. Other detailed specifications and features of AHU/indoor units. Refer to sample Table shown below.

Sample Table A-1-1: Equipment Design Capacity and Distribution Plan (Schedule of Equipment)

Item No.	Area/	Area in Sq.M.	Detailed Specifications (Quantity, Capacity, Type of Units, Sound Level (dBA), etc...)
1	Meeting Room 1	() Specific area 1,419 m ² (total area)	1 unit – 50TR Inverter-type, DX-Type, Air Handling Units, other features (enumerate in details as required)

- 6. Make and submit a detailed System Design Plan and Schedule of Equipment (use long-bond paper size only) showing and listing the number (quantity), type, model, rated cooling capacity [(kW and tons (TR) as well as in horsepower], and the total and individual kilowatt input of indoor unit and outdoor unit for Meeting Room 1. Refer to sample tabulation below for basic guideline:

Sample Table A-1-2: Sample Basic System Design Plan and Equipment Schedule

Cluster No.	Area Served	Outdoor Units		Connected Indoor Units	
		Qty-Unit	Description	Qty-Unit	Description
1	Meetin g	1 lot	__ kW (50 TR) consisting of:	1 unit	Air Handling Unit Ducted

	Room 1		4 units ___ kW (12.5TR)capacit y, model _____		Type, ___ kW (50TR), Model _____
--	-----------	--	---	--	--

7. Make and submit a more detailed installation plan and drawings using A3 size bond-paper showing all necessary details based on the PICC-supplied floor plan, list of indoor units, capacity design and distribution plan (equipment schedule), system design plan, proposed location of outdoor unit/s, actual conditions observed, and other conditions.
8. Make and submit a detailed single-line electrical layout/drawing using A3 size bond-paper showing all necessary details for feeder lines, control wirings, control panels, circuit breakers with capacities, watt-hour meter and all other accessories.
9. Install the above-mentioned units, accessories and materials for their proper operation in Meeting Room 1. Replace existing Packaged Air Handling Unit serving MR 1 at the AHU Room at 4/F of Delegation Building, following proper alignment and uniform distances for proper air distribution and aesthetics with appropriate hangers, vibration isolator, and supports bolted to the floor slab. Use proper size support-base and frames to avoid wagging expansion bolts.
Install the AHU/indoor units based on the capacity design plan and layout as shown in Table A-1: General Equipment Capacity Design and Distribution Plan (Schedule of Equipment), Basic System Design Plan (refer to Sample Table A-1-2) and Installation Plan/Drawing (size-30" x 40") and electrical layout (size-30" x 40") as part of submittals by the Contractor during implementation stage.
Dismantle properly/carefully any air duct and building accessories obstructing the proper installation of the unit.
10. Install outdoor units at the Roof Deck of Delegation Building considering the best location for aesthetics for Air-Cooled Condensing Units (ACCUs). Said ACCUs shall be installed with gauge no. 20, GI air deflector with louver enclosure as specified in Item 1.20. Fabricate angular metal (2inches x 2inches x 1/4 inches) base/stand and metal support brackets with footings embedded on a concrete base, 5ft. (L) x 3 ft. (W) x 5 inches (T), or as appropriately required per actual outdoor unit sizes. Concrete footing/base shall be properly formed and cured atop the said existing water-proofed deck. Restore damaged areas affected by the contractor's works.
11. Re-route or relocate air duct, electrical conduits and other materials obstructing the installation area of the indoor unit/refrigerant pipes. Free the installation area of any obstruction and restore the functionality of those re-routed facilities or building/system attachment.
12. Restore the affected water proofing during installation of outdoor units at roof deck using same kind/type of waterproofing materials as per contractor's required specifications. Make a detailed plan prior for the restoration of the affected area before implementation.

13. Install the above units using appropriate size hard-drawn copper tubing and fittings. All field connection must be soldered type to minimize refrigerant and oil leakage and system troubles.
14. Insulate the suction lines, condensate drain pipes and other pipe lines required by manufacturer using one-inch (1") thick closed-cell rubber insulation, Aeroflex or approved equivalent (to be approved by PICC-MSD Assistant Director/TSD Director) complete with aluminum cladding.
15. Provide and install all electrical and control system requirements as well as accessories with capacities and specifications properly designed according to the best practices in the industry, Philippine Electrical Code, NEMA and other applicable local and international codes. All electrical/electronic system requirements shall include electrical wires – THHN for main supply cables, feeder lines and control lines, steel conduits/Intermediate Metal Conduit (IMC) or approved equal, panel boards/enclosure – weather-proof, transformer primary and secondary circuit breakers, Outdoor and indoor units main circuit breakers and sub-breakers - Square D, G.E. or approved equal, magnetic starter with overload relay- Fujihaya or approved equal (to be approved by PICC-MSD Assistant Director/TSD Director), controllers, and accessories for the power supply and control system of the above air conditioners.
16. Install Watt-hour meter/s, digital, 3 phase 3 wires, CT rated, 230 volts, with RS232 communication, panel mounted, complete with the required current transformers, compatible with building management system (BMS) connection for the proper monitoring and/or recording of the total power consumption of the air conditioning units/system to be installed at Meeting Room 1. Install one-unit watt-hour meter to monitor and record the total consumption of both the outdoor units and indoor units/system if all the aircon units are connected to one (1) source of power supply. However, if all the aircon units are connected to different sources of power supply, install multiple units watt-hour meter to monitor and record the total consumption of both the outdoor units and indoor units/system connected to all sources of power supply
17. Paint all angle bars, conduit and other metallic component with two coat epoxy paint, cord or approved equal. Paint for electrical conduit shall be color orange and for angle bars shall be color gray.
18. Always clean the working area on daily basis and haul the dismantled building or system accessories and components carefully to temporary designated area. All garbage shall be hauled outside the PICC premises at the Contractor's expense.
19. Conduct operation testing and commissioning of the new PAHU and outdoor unit together with the PICC representative from Mechanical Services Division, and record all actual operating data as follows:
 - 19.1. Pre-cooling room temperature (Fahrenheit and Celsius) at 30 minutes and one (1) hour after start-up of all units operating at full or high speed.

- 19.2. Ambient or atmospheric temperature (Fahrenheit and Celsius)
 - 19.3. Supply voltage and current (amperage) of every line/phase of each indoor unit and outdoor unit. Current (amperage) during operation should not be more than the rated full load amperage of each unit (indoor and outdoor). Otherwise, it should be treated as abnormal condition and will not be accepted until the unit is replaced with a new unit with good operating condition. Also, full payment will not be processed.
 - 19.4. Standing pressure of the refrigerant system prior to test operation.
 - 19.5. Suction and discharge pressure and temperature of the refrigerant system
 - 19.6. Sound pressure level (SPL A-weighting) of each unit (indoor and outdoor unit) in decibel (dBA) and the total sound pressure level of the room when all indoor units are operating at the same time. Actual sound pressure level of each fan speed of indoor unit shall be tested and recorded. SPL testing must be conducted during night time and when there is no other equipment/system operating at the same time to minimize ambient noise condition.
- Note: All sound pressure levels should conform with the requirement otherwise the unit will not be accepted and full payment will not be processed until the unit is replaced or the problem is corrected.
- 19.7. Good operating condition of the PAHU/system.
 - 19.8. Other actual operating parameters.

20. Turn-over the air conditioning unit and its accessories as well as other affected building attachment/facilities in good order condition.

IV. GENERAL CONDITIONS:

- 1. The contractor must conduct site survey and inspection.
- 2. Any work that may affect the operation and security measures of PICC shall be coordinated properly and shall be done in accordance with the PICC' approved schedule.
- 3. As a requirement, the contractor must have in its organization or assign personnel, at least a licensed/registered mechanical engineer personnel during the implementation of the project.
- 4. Welding works or any "hot work" requirement of the project must be coordinated with the project-in-Charge and seek approval from the TSD Director prior to implementation.
- 5. All ceiling mounted indoor units must be installed at the ceiling with rigid metal support using angle bars with ¼" thick (engineering standard and not commercial standard).

6. Pipe runs must have a support post or brackets, 2 meters apart. (Use 1x1 angle bar and G.I. U-bolt set).
7. All electrical works, size of wires, circuit breakers, wirings, safety gadgets and controllers must conform with the standard practice in the industry and in accordance with the Electrical Code of the Philippines, NEMA and other applicable local and international codes for safety.
8. The system must be in full charge of appropriate compressor oil and refrigerant 410A or R32 to ensure long life and continuous reliability of equipment/system operation.
9. The contractor after final testing of the equipment must submit the equipment test operation result for each equipment as specified below as part of attachment for second and/or final payment.
 - 9.1 Pre-cooling room temperature (Fahrenheit and Celsius) at 30 minutes and one (1) hour after start-up of all units operating at full or high speed.
 - 9.2. Ambient or atmospheric temperature (Fahrenheit and Celsius)
 - 9.3. Supply voltage and current (amperage) of every line/phase of each indoor unit and outdoor unit. Current (amperage) during operation should not be more than the rated full load amperage of each unit (indoor and outdoor). Otherwise, it should be treated as abnormal condition and will not be accepted until the unit is replaced with a new unit with good operating condition. Also, full payment will not be processed.
 - 9.4. Standing pressure of the refrigerant system prior to test operation.
 - 9.5. Suction and discharge pressure and temperature of the refrigerant system
 - 9.6. Sound pressure level (SPL A-weighting) of each unit (indoor and outdoor unit) in decibel (dBA) and the total sound pressure level of the room when all indoor units are operating at the same time. Actual sound pressure level of each fan speed of indoor unit shall be tested and recorded. SPL testing must be conducted during night time and when there is no other equipment/system operating at the same time to minimize ambient noise condition. Note: All sound pressure levels should conform to the requirement otherwise the unit will not be accepted and full payment will not be processed until the unit is replaced or the problem is corrected.
 - 9.7. Air Volume Flow Rate Test Report.
 - 9.8. Air Balancing Report
 - 9.9. Other actual operating parameters.
10. All metal supports, hangers, brackets, clamps and bases of the A/C units/equipment must be painted with epoxy primer gray, one (1) coat and two (2) coats epoxy paint gray finish.

11. The contractor shall report to PICC on or before the bidding, any perceived or evident condition that would prevent him from performing first class work.
12. The Contractor must submit NBI or Barangay Clearance of its personnel to be assigned at the PICC.
13. The Contractor warrants that its personnel and/or representatives to be assigned shall comply with and submit themselves to the PICC' policies, procedures, rules and regulation concerning security, safety, health, environmental protection, energy conservation, coordination system, materials and parts issuance, etc. Contractor's personnel to be assigned for the project must be in uniform with IDs throughout the duration of the project.
14. The Contractor should free the PICC and its personnel from and against all liabilities arising from injuries or liabilities to persons or damages to property occasioned by any act or omissions by the Contractor including any and all expenses, legal or otherwise which may be incurred by PICC and its personnel in the defence of any claim, action or suit.

V. TRAINING:

The winning contractor must conduct seminar and training sessions for the transfer of technology and technical know-how for the proper installation, operation, maintenance, and repair of Inverter-Type, DX-type, AHU air-conditioning system before and after the installation and commissioning. Also, it must conduct seminar on the proper use of design software in the proper designing of Inverter-Type, DX-type, AHU system for the future requirement of the Center.

As part of the training program, the contractor should allow any assigned personnel of PICC-Mechanical Services Division for on-the-job training during installation and commissioning and monthly check-up and servicing for a one-year warranty period.

The contractor must recommend:

1. Proper maintenance forms for observations, monitoring and recording operational data and trouble.
2. Proper periodic maintenance check-up activities and standard operating procedures on daily, weekly, monthly, quarterly and annual basis.

STATEMENT OF COMPLIANCE

Bidders must state here either "Comply" or "Not Comply" against each of the individual parameters of each Specification stating the corresponding performance parameter of the equipment offered.

Note:

Statements of "Comply" or "Not Comply" must be supported by evidence in a Bidders Bid and cross-referenced to that evidence. Evidence shall be in the form of manufacturer's un-amended sales literature, unconditional statements of specification and compliance issued by the manufacturer, samples, independent test data etc., as appropriate. A statement that is not supported by evidence or is subsequently found to be contradicted by the evidence presented will render the Bid under evaluation liable for rejection. A statement either in the Bidder's statement of compliance or the supporting evidence that is found to be false either during Bid evaluation, post-qualification or the execution of the Contract may be regarded as fraudulent and render the Bidder or supplier liable for prosecution subject to the applicable laws and issuances.

LOCATION: FOURTH FLOOR DELEGATION BLDG.

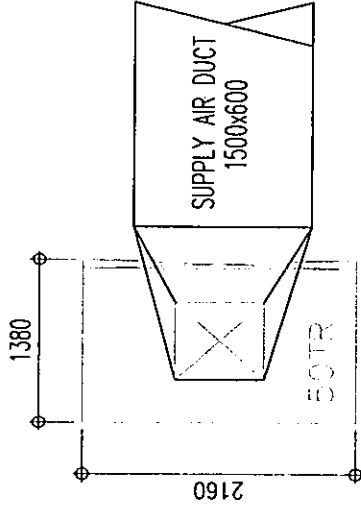
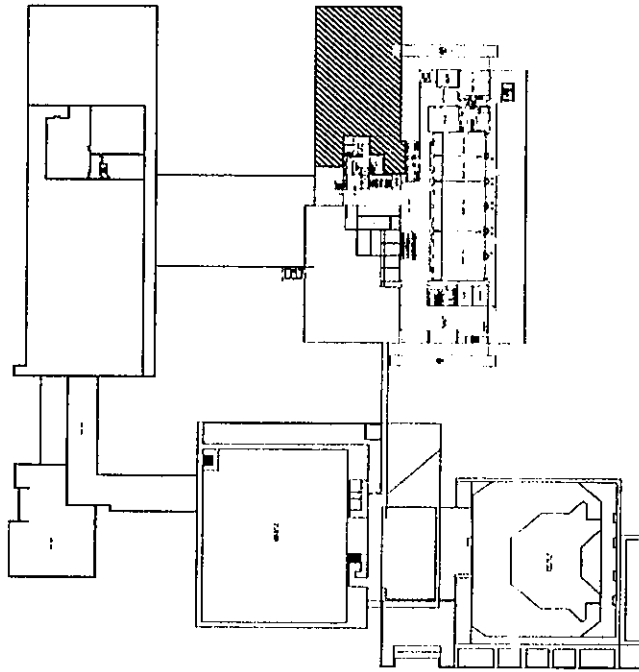



NOTE:

1. EXISTING WATER COOLED AIR HANDLING UNIT (AHU) TO BE DISMANTLED AND REPLACED BY NEW EQUIPMENT. (SEE TECHNICAL SPECIFICATIONS)
2. THE CONTRACTOR/SERVICE PROVIDER SHALL VERIFY THE ACTUAL DIMENSIONS AT SITE.
3. AIR COOLED CONDENSING UNITS (ACCU) SHALL INSTALL AT ROOFDECK OF DELEGATION BLDG.

PROPOSED REPLACEMENT OF ONE (1) UNIT AHU EQUIPMENT
SERVING MEETING ROOM-1 AT DELEGATION BUILDING

1/28 SCALE:

NIS

 PICC Philippine International Convention Center	TITLE	DATE	PREPARED BY	RECOMMENDING FOR APPROVAL	APPROVED BY
	PROPOSED REPLACEMENT OF AIR HANDLING UNIT EQUIPMENT LOCATION PICC COMPLEX, PASAY CITY	01-28-2025	ENGR. ROY ANTON SUBALDO SHIFT SUPERVISING TECHNICIAN, MSD	ENGR. WILSON B. DELOS REYES DIRECTOR, ISD	 ATTY. NICOLETTE ANN P. CRUZ GENERAL MANAGER
	REVISION	CHECKED BY			
	00	ENGR. MARNO B. MACANAS ASSISTANT DIRECTOR, MSD			