

# PHILIPPINE INTERNATIONAL CONVENTION CENTER



**PROJECT TITLE : SUPPLY OF LABOR AND MATERIALS FOR  
THE REPLACEMENT OF BULLET  
RESISTANT GLASS DOORS OF HEROES  
ROOM (RE-BID)**

**ABC : ₱1,865,855.00**

**Reference/s : PICC APP2023 – MC - 15**

**ITB-2023  
April 17, 2023**

# TABLE OF CONTENTS

<b>Glossary of Terms, Abbreviations, and Acronyms.....</b>	<b>2</b>
<b>Section I. Invitation to Bid .....</b>	<b>4</b>
<b>Section II. Instruction to Bidders .....</b>	<b>7</b>
1. Scope of Bid .....	8
2. Funding Information .....	8
3. Bidding Requirements .....	8
4. Corrupt, Fraudulent, Collusive and Coercive Practices .....	8
5. Eligible Bidders .....	8
6. Origin of Goods.....	9
7. Subcontracts .....	9
8. Pre-bid Conference .....	10
9. Clarification and Amendments of Bidding Documents .....	10
10. Documents Comprising the Bid: Eligibility and Technical Component .....	10
11. Documents Comprising the Bid: Financial Component .....	10
12. Bid Prices .....	11
13. Bid and Payment Currencies .....	11
14. Bid Security .....	12
15. Sealing and Marking of Bids .....	12
16. Deadline for Submission of Bids .....	12
17. Opening and Preliminary Examination of Bids.....	12
18. Domestic Preference.....	13
19. Detailed Evaluation and Comparison of Bids .....	13
20. Post Qualification .....	13
21. Signing of the Contract .....	13
<b>Section III. Bid Data Sheet.....</b>	<b>14</b>
<b>Section IV. General Conditions of Contract.....</b>	<b>17</b>
1. Scope of Contract .....	18
2. Advance Payment and Terms of Payment.....	18
3. Performance Security .....	18
4. Inspection and Test.....	18
5. Warranty .....	19
6. Liability of the Supplier .....	19
<b>Section V. Special Conditions of Contract .....</b>	<b>20</b>
<b>Section VI. Schedule of Requirements .....</b>	<b>23</b>
<b>Section VII. Technical Specifications .....</b>	<b>24</b>
<b>Section VIII. Checklist of Technical and Financial Documents .....</b>	<b>43</b>

# *Glossary of Terms, Abbreviations, and Acronyms*

**ABC** – Approved Budget for the Contract.

**ARCC** – Allowable Range of Contract Cost.

**BAC** – Bids and Awards Committee.

**Bid** – A signed offer or proposal to undertake a contract submitted by a bidder in response to and in consonance with the requirements of the bidding documents. Also referred to as *Proposal* and *Tender*. (2016 revised IRR, Section 5[c])

**Bidder** – Refers to a contractor, manufacturer, supplier, distributor and/or consultant who submits a bid in response to the requirements of the Bidding Documents. (2016 revised IRR, Section 5[d])

**Bidding Documents** – The documents issued by the Procuring Entity as the bases for bids, furnishing all information necessary for a prospective bidder to prepare a bid for the Goods, Infrastructure Projects, and/or Consulting Services required by the Procuring Entity. (2016 revised IRR, Section 5[e])

**BIR** – Bureau of Internal Revenue.

**BSP** – Bangko Sentral ng Pilipinas.

**CDA** – Cooperative Development Authority.

**Consulting Services** – Refer to services for Infrastructure Projects and other types of projects or activities of the GOP requiring adequate external technical and professional expertise that are beyond the capability and/or capacity of the GOP to undertake such as, but not limited to: (i) advisory and review services; (ii) pre-investment or feasibility studies; (iii) design; (iv) construction supervision; (v) management and related services; and (vi) other technical services or special studies. (2016 revised IRR, Section 5[i])

**Contract** – Refers to the agreement entered into between the Procuring Entity and the Supplier or Manufacturer or Distributor or Service Provider for procurement of Goods and Services; Contractor for Procurement of Infrastructure Projects; or Consultant or Consulting Firm for Procurement of Consulting Services; as the case may be, as recorded in the Contract Form signed by the parties, including all attachments and appendices thereto and all documents incorporated by reference therein.

**Contractor** – is a natural or juridical entity whose proposal was accepted by the Procuring Entity and to whom the Contract to execute the Work was awarded. Contractor as used in these Bidding Documents may likewise refer to a supplier, distributor, manufacturer, or consultant.

**CPI** – Consumer Price Index.

**DOLE** – Department of Labor and Employment.

**DTI** – Department of Trade and Industry.

**Foreign-funded Procurement or Foreign-Assisted Project** – Refers to procurement whose funding source is from a foreign government, foreign or international financing institution as specified in the Treaty or International or Executive Agreement. (2016 revised IRR, Section 5[b]).

**GFI** – Government Financial Institution.

**GOCC** – Government-owned and/or –controlled corporation.

**Goods** – Refer to all items, supplies, materials and general support services, except Consulting Services and Infrastructure Projects, which may be needed in the transaction of public businesses or in the pursuit of any government undertaking, project or activity, whether in the

nature of equipment, furniture, stationery, materials for construction, or personal property of any kind, including non-personal or contractual services such as the repair and maintenance of equipment and furniture, as well as trucking, hauling, janitorial, security, and related or analogous services, as well as procurement of materials and supplies provided by the Procuring Entity for such services. The term “related” or “analogous services” shall include, but is not limited to, lease or purchase of office space, media advertisements, health maintenance services, and other services essential to the operation of the Procuring Entity. (2016 revised IRR, Section 5[r])

**GOP** – Government of the Philippines.

**Infrastructure Projects** – Include the construction, improvement, rehabilitation, demolition, repair, restoration or maintenance of roads and bridges, railways, airports, seaports, communication facilities, civil works components of information technology projects, irrigation, flood control and drainage, water supply, sanitation, sewerage and solid waste management systems, shore protection, energy/power and electrification facilities, national buildings, school buildings, hospital buildings, and other related construction projects of the government. Also referred to as *civil works or works*. (2016 revised IRR, Section 5[u])

**LGUs** – Local Government Units.

**NFCC** – Net Financial Contracting Capacity.

**NGA** – National Government Agency.

**PCAB** – Philippine Contractors Accreditation Board.

**PhilGEPS** - Philippine Government Electronic Procurement System.

**Procurement Project** – refers to a specific or identified procurement covering goods, infrastructure project or consulting services. A Procurement Project shall be described, detailed, and scheduled in the Project Procurement Management Plan prepared by the agency which shall be consolidated in the procuring entity's Annual Procurement Plan. (GPPB Circular No. 06-2019 dated 17 July 2019)

**PSA** – Philippine Statistics Authority.

**SEC** – Securities and Exchange Commission.

**SLCC** – Single Largest Completed Contract.

**UN** – United Nations.

## *Section I. Invitation to Bid*



## BIDS AND AWARDS COMMITTEE

### Invitation to Re-Bid for the Supply of Labor and Materials for the Replacement of Bullet Resistant Glass Doors of Heroes Room

1. The *Philippine International Convention Center (PICC)*, through the *Approved Budget for CY 2023*, intends to apply the sum of **ONE MILLION EIGHT HUNDRED SIXTY-FIVE THOUSAND EIGHT HUNDRED FIFTY-FIVE PESOS (Php1,865,855.00), VAT Inclusive**, being the Approved Budget for the Contract (ABC) to payments under the contract for the **Supply of Labor and Materials for the Replacement of Bullet Resistant Glass Doors of Heroes Room**. Bids received in excess of ABC shall be automatically rejected at bid opening.
2. The *PICC* now invites bids for the abovementioned requirement. Bidders should have completed, within at least five (5) years from the date of submission and receipt of bids, a contract similar to the abovementioned requirement. The description of an eligible bidder is contained in the Bidding Documents, particularly, in Section II (Instructions to Bidders).
3. Bidding will be conducted through open competitive bidding procedures using a non-discretionary “*pass/fail*” criterion as specified in the 2016 revised Implementing Rules and Regulations (IRR) of Republic Act (RA) No. 9184.
4. Prospective Bidders may obtain further information from the *PICC-BAC* and inspect the Bidding Documents at the address given below during office hours.
5. A complete set of Bidding Documents may be acquired by prospective bidders starting May 18, 2023 from the given address and website(s) below and *upon payment of a non-refundable fee in the amount of Two Thousand Pesos (Php2,000.00)*. A bidder shall present its proof of payment for the fee *by furnishing the PICC-BAC a copy of the Official Receipt*.
6. Bids must be duly received by the BAC Secretariat through manual submission at the office address indicated below, on or before June 1, 2023 at 9:30 a.m. Late bids shall not be accepted.
7. All Bids must be accompanied by a bid security in any of the acceptable forms and in the amount stated in **ITB** Clause 14.
8. Bid opening shall be on June 1, 2023, at 10:00 a.m. at the given address below. Bids will be opened in the presence of the bidders’ representatives who choose to attend the activity.

9. The *PICC* reserves the right to reject any and all bids, declare a failure of bidding, or not award the contract at any time prior to contract award in accordance with Sections 35.6 and 41 of the 2016 revised IRR of RA No. 9184, without thereby incurring any liability to the affected bidder or bidders.
10. For further information, please refer to:

*BIDS AND AWARDS COMMITTEE  
PHILIPPINE INTERNATIONAL CONVENTION CENTER  
PICC Complex, Pasay City 1307  
87894759 and 87894760  
Telefax No. 87894761  
Email: [procurement@picc.gov.ph](mailto:procurement@picc.gov.ph)*

11. You may visit the following websites:

For downloading of Bidding Documents: [www.picc.gov.ph](http://www.picc.gov.ph)

*[Date of Issue]*

  
MELPIN A. GONZAGA  
Chairman



## *Section II. Instructions to Bidders*



## **1. Scope of Bid**

The Procuring Entity, *Philippine International Convention Center* wishes to receive Bids for the *Supply of labor and Materials for the Replacement of Bullet Resistant Glass Doors of Heroes Room* with identification numbers *PICC APP2023-MC -15*.

## **2. Funding Information**

2.1. The GOP through the source of funding as indicated below for 2023 in the total amount of PhP1,865,855.00.

2.2. The source of funding is:

- a. GOCC and GFIs, the Corporate Operating Budget.

## **3. Bidding Requirements**

The Bidding for the Project shall be governed by all the provisions of RA No. 9184 and its 2016 revised IRR, including its Generic Procurement Manuals and associated policies, rules and regulations as the primary source thereof, while the herein clauses shall serve as the secondary source thereof.

Any amendments made to the IRR and other GPPB issuances shall be applicable only to the ongoing posting, advertisement, or **IB** by the BAC through the issuance of a supplemental or bid bulletin.

The Bidder, by the act of submitting its Bid, shall be deemed to have verified and accepted the general requirements of this Project, including other factors that may affect the cost, duration and execution or implementation of the contract, project, or work and examine all instructions, forms, terms, and project requirements in the Bidding Documents.

## **4. Corrupt, Fraudulent, Collusive, and Coercive Practices**

The Procuring Entity, as well as the Bidders and Suppliers, shall observe the highest standard of ethics during the procurement and execution of the contract. They or through an agent shall not engage in corrupt, fraudulent, collusive, coercive, and obstructive practices defined under Annex "I" of the 2016 revised IRR of RA No. 9184 or other integrity violations in competing for the Project.

## **5. Eligible Bidders**

5.1. Only Bids of Bidders found to be legally, technically, and financially capable will be evaluated.

5.2. Foreign ownership limited to those allowed under the rules may participate in this Project.

- 5.3. Pursuant to Section 23.4.1.3 of the 2016 revised IRR of RA No.9184, the Bidder shall have an SLCC that is at least one (1) contract similar to the Project the value of which, adjusted to current prices using the PSA's CPI, must be at least equivalent to:
- a. For the procurement of Non-expendable Supplies and Services: The Bidder must have completed a single contract that is similar to this Project, equivalent to at least fifty percent (50%) of the ABC.
- 5.4. The Bidders shall comply with the eligibility criteria under Section 23.4.1 of the 2016 IRR of RA No. 9184.

## 6. Origin of Goods

There is no restriction on the origin of goods other than those prohibited by a decision of the UN Security Council taken under Chapter VII of the Charter of the UN, subject to Domestic Preference requirements under **ITB** Clause 18.

## 7. Subcontracts

- 7.1. The Bidder may subcontract portions of the Project to the extent allowed by the Procuring Entity as stated herein, but in no case more than twenty percent (20%) of the Project.

The Procuring Entity has prescribed that:

- a. Subcontracting is not allowed.
- 7.2. *[If Procuring Entity has determined that subcontracting is allowed during the bidding, state:]* The Bidder must submit together with its Bid the documentary requirements of the subcontractor(s) complying with the eligibility criteria stated in **ITB** Clause 5 in accordance with Section 23.4 of the 2016 revised IRR of RA No. 9184 pursuant to Section 23.1 thereof.
- 7.3. *[If subcontracting is allowed during the contract implementation stage, state:]* The Supplier may identify its subcontractor during the contract implementation stage. Subcontractors identified during the bidding may be changed during the implementation of this Contract. Subcontractors must submit the documentary requirements under Section 23.1 of the 2016 revised IRR of RA No. 9184 and comply with the eligibility criteria specified in **ITB** Clause 5 to the implementing or end-user unit.
- 7.4. Subcontracting of any portion of the Project does not relieve the Supplier of any liability or obligation under the Contract. The Supplier will be responsible for the acts, defaults, and negligence of any subcontractor, its agents, servants, or workmen as fully as if these were the Supplier's own acts, defaults, or negligence, or those of its agents, servants, or workmen.

## 8. Pre-Bid Conference

The Procuring Entity will hold a pre-bid conference for this Project on the specified date and time and either at its physical address at and/or through videoconferencing/webcasting as indicated in paragraph 6 of the **IB**.

## 9. Clarification and Amendment of Bidding Documents

Prospective bidders may request for clarification on and/or interpretation of any part of the Bidding Documents. Such requests must be in writing and received by the Procuring Entity, either at its given address or through electronic mail indicated in the **IB**, at least ten (10) calendar days before the deadline set for the submission and receipt of Bids.

## 10. Documents comprising the Bid: Eligibility and Technical Components

- 10.1. The first envelope shall contain the eligibility and technical documents of the Bid as specified in **Section VIII (Checklist of Technical and Financial Documents)**.
- 10.2. The Bidder's SLCC as indicated in **ITB** Clause 5.3 should have been completed within the last three (3) years prior to the deadline for the submission and receipt of bids.
- 10.3. If the eligibility requirements or statements, the bids, and all other documents for submission to the BAC are in foreign language other than English, it must be accompanied by a translation in English, which shall be authenticated by the appropriate Philippine foreign service establishment, post, or the equivalent office having jurisdiction over the foreign bidder's affairs in the Philippines. Similar to the required authentication above, for Contracting Parties to the Apostille Convention, only the translated documents shall be authenticated through an apostille pursuant to GPPB Resolution No. 13-2019 dated 23 May 2019. The English translation shall govern, for purposes of interpretation of the bid.

## 11. Documents comprising the Bid: Financial Component

- 11.1. The second bid envelope shall contain the financial documents for the Bid as specified in **Section VIII (Checklist of Technical and Financial Documents)**.
- 11.2. If the Bidder claims preference as a Domestic Bidder or Domestic Entity, a certification issued by DTI shall be provided by the Bidder in accordance with Section 43.1.3 of the 2016 revised IRR of RA No. 9184.
- 11.3. Any bid exceeding the ABC indicated in paragraph 1 of the **IB** shall not be accepted.
- 11.4. For Foreign-funded Procurement, a ceiling may be applied to bid prices provided the conditions are met under Section 31.2 of the 2016 revised IRR of RA No. 9184.

## 12. Bid Prices

12.1. Prices indicated on the Price Schedule shall be entered separately in the following manner:

- a. For Goods offered from within the Procuring Entity's country:
  - i. The price of the Goods quoted EXW (ex-works, ex-factory, ex-warehouse, ex-showroom, or off-the-shelf, as applicable);
  - ii. The cost of all customs duties and sales and other taxes already paid or payable;
  - iii. The cost of transportation, insurance, and other costs incidental to delivery of the Goods to their final destination; and
  - iv. The price of other (incidental) services, if any, listed in e.
- b. For Goods offered from abroad:
  - i. Unless otherwise stated in the **BDS**, the price of the Goods shall be quoted delivered duty paid (DDP) with the place of destination in the Philippines as specified in the **BDS**. In quoting the price, the Bidder shall be free to use transportation through carriers registered in any eligible country. Similarly, the Bidder may obtain insurance services from any eligible source country.
  - ii. The price of other (incidental) services, if any, as listed in **Section VII (Technical Specifications)**.

## 13. Bid and Payment Currencies

13.1. For Goods that the Bidder will supply from outside the Philippines, the bid prices may be quoted in the local currency or tradeable currency accepted by the BSP at the discretion of the Bidder. However, for purposes of bid evaluation, Bids denominated in foreign currencies, shall be converted to Philippine currency based on the exchange rate as published in the BSP reference rate bulletin on the day of the bid opening.

13.2. Payment of the contract price shall be made in:

- a. Philippine Pesos.

## **14. Bid Security**

- 14.1. The Bidder shall submit a Bid Securing Declaration<sup>1</sup> or any form of Bid Security in the amount indicated in the **BDS**, which shall be not less than the percentage of the ABC in accordance with the schedule in the **BDS**.
- 14.2. The Bid and bid security shall be valid one hundred twenty (120) calendar days from the date of opening of bids. Any Bid not accompanied by an acceptable bid security shall be rejected by the Procuring Entity as non-responsive.

## **15. Sealing and Marking of Bids**

Each Bidder shall submit one copy of the first and second components of its Bid.

The Procuring Entity may request additional hard copies and/or electronic copies of the Bid. However, failure of the Bidders to comply with the said request shall not be a ground for disqualification.

If the Procuring Entity allows the submission of bids through online submission or any other electronic means, the Bidder shall submit an electronic copy of its Bid, which must be digitally signed. An electronic copy that cannot be opened or is corrupted shall be considered non-responsive and, thus, automatically disqualified.

## **16. Deadline for Submission of Bids**

- 16.1. The Bidders shall submit on the specified date and time and either at its physical address or through online submission as indicated in paragraph 7 of the **IB**.

## **17. Opening and Preliminary Examination of Bids**

- 17.1. The BAC shall open the Bids in public at the time, on the date, and at the place specified in paragraph 9 of the **IB**. The Bidders' representatives who are present shall sign a register evidencing their attendance. In case videoconferencing, webcasting or other similar technologies will be used, attendance of participants shall likewise be recorded by the BAC Secretariat.

In case the Bids cannot be opened as scheduled due to justifiable reasons, the rescheduling requirements under Section 29 of the 2016 revised IRR of RA No. 9184 shall prevail.

- 17.2. The preliminary examination of bids shall be governed by Section 30 of the 2016 revised IRR of RA No. 9184.

---

<sup>1</sup> In the case of Framework Agreement, the undertaking shall refer to entering into contract with the Procuring Entity and furnishing of the performance security or the performance securing declaration within ten (10) calendar days from receipt of Notice to Execute Framework Agreement.

## 18. Domestic Preference

- 18.1. The Procuring Entity will grant a margin of preference for the purpose of comparison of Bids in accordance with Section 43.1.2 of the 2016 revised IRR of RA No. 9184.

## 19. Detailed Evaluation and Comparison of Bids

- 19.1. The Procuring BAC shall immediately conduct a detailed evaluation of all Bids rated "*passed*," using non-discretionary pass/fail criteria. The BAC shall consider the conditions in the evaluation of Bids under Section 32.2 of the 2016 revised IRR of RA No. 9184.
- 19.2. Except for bidders submitting a committed Line of Credit from a Universal or Commercial Bank in lieu of its NFCC computation, all Bids must include the NFCC computation pursuant to Section 23.4.1.4 of the 2016 revised IRR of RA No. 9184, which must be sufficient for the total of the ABCs for all the lots or items participated in by the prospective Bidder. For bidders submitting the committed Line of Credit, it must be at least equal to ten percent (10%) of the ABCs for all the lots or items participated in by the prospective Bidder.

## 20. Post-Qualification

- 20.2. Within a non-extendible period of five (5) calendar days from receipt by the Bidder of the notice from the BAC that it submitted the Lowest Calculated Bid, the Bidder shall submit its latest income and business tax returns filed and paid through the BIR Electronic Filing and Payment System (eFPS) and other appropriate licenses and permits required by law and stated in the **BDS**.



## 21. Signing of the Contract

- 21.1. The documents required in Section 37.2 of the 2016 revised IRR of RA No. 9184 shall form part of the Contract. Additional Contract documents are indicated in the **BDS**.

### *III. Bid Data Sheet*

# Bid Data Sheet

ITB Clause	
5	<p>The following persons shall be eligible to participate in this bidding:</p> <ol style="list-style-type: none"> <li>a. Duly licensed Filipino citizens/sole proprietorships;</li> <li>b. Partnerships duly organized under the laws of the Philippines and of which at least sixty percent (60%) of the interest belongs to citizens of the Philippines;</li> <li>c. Corporations duly organized under the laws of the Philippines and of which at least sixty percent (60%) of the of the outstanding capital stock belongs to citizens of the Philippines;</li> <li>d. Cooperatives duly organized under the laws of the Philippines and of which at least sixty percent (60%) of the interest belongs to citizens of the Philippines: and</li> <li>e. Must be engaged in business for the supply, installation and/or repair of bullet resistant glass doors.</li> </ol>
5.3	<p>For this purpose, similar contract shall refer to supply, installation and/or repair of <i>25mm thick</i> glass doors</p> <p>The Bidder must have completed within the last <i>ten (10) years</i> a single contract that is similar to this requirement, the amount of which shall be at least fifty percent (50%) of the ABC.</p>
7.1	Sub-contracting is not allowed
12	Not applicable
14.1	<p>The bid security shall be in the form of a Bid Securing Declaration, or any of the following forms and amounts:</p> <ol style="list-style-type: none"> <li>a. In the amount of not less than ₱37,317.10, Cash, cashier's/manager's check, bank draft/guarantee or irrevocable letter of credit;</li> <li>b. Surety Bond in the amount of not less than ₱93,292.75.</li> </ol>
15	<p>Sealing and Marking of Bids</p> <p>Each Bidder shall submit the original and one (1) copy of the first and second components of its Bid.</p>
16.1	<p>The address for submission of bids is:</p> <p style="text-align: center;">PICC-Bids and Awards Committee (BAC) Secretariat Ground floor, Delegation Building PICC Complex, 1307 Pasay City</p> <p>The deadline for submission of bids is June 1, 2023 at 9:30 a.m.</p>



17.1	<p>The place of bid</p> <p style="text-align: center;"><b>BAC CONFERENCE ROOM</b>  Function Room B, 2<sup>nd</sup> Floor, Secretariat Building  PICC Complex, 1307 Pasay City</p> <p>The date and time of bid opening is June 1, 2023 at 10:00 a.m.</p> <p>In case the Bids cannot be opened as scheduled due to justifiable reasons, the BAC shall take custody of the Bids submitted and the opening of Bids shall be at 2:00 p.m. of the next working day.</p>
19.3	<p>Total ABC is <b>ONE MILLION EIGHT HUNDRED SIXTY-FIVE THOUSAND EIGHT HUNDRED FIFTY-FIVE PESOS (PhP1,865,855.00), VAT Inclusive.</b></p>
20.2	<p>Within a non-extendible period of five (5) calendar days from receipt by the bidder of the notice from the BAC that it submitted the LCB, the Bidder shall submit the following documentary requirements:</p> <ol style="list-style-type: none"> <li>a. Certified Photocopy of the CY 2021 Income and Business Tax Returns with proof of payment;</li> <li>b. Sections III and V of the bid documents, signed on each and every page by the bidder's authorized representative;</li> <li>c. Company Profile with sketch of office location;</li> <li>d. Certifications that the participating bidder has conducted ocular inspection of the above subject requirements; and</li> <li>e. Certificate of Satisfactory Completion &amp; Acceptance of previous PICC projects undertaken within the last five (5) years, if any.</li> </ol>
21	<p>The following documents shall be submitted, together with the Performance Bond, within ten (10) calendar days after the receipt of the Notice of Award. Such documents shall form part of the contract;</p> <ol style="list-style-type: none"> <li>1. Project Schedule/ Work Program; and</li> <li>2. Project Safety and Health Program signed by the Safety Officer.</li> </ol>

*f.* 

## *Section IV. General Conditions of Contract*

## 1. Scope of Contract

This Contract shall include all such items, although not specifically mentioned, that can be reasonably inferred as being required for its completion as if such items were expressly mentioned herein. All the provisions of RA No. 9184 and its 2016 revised IRR, including the Generic Procurement Manual, and associated issuances, constitute the primary source for the terms and conditions of the Contract, and thus, applicable in contract implementation. Herein clauses shall serve as the secondary source for the terms and conditions of the Contract.

This is without prejudice to Sections 74.1 and 74.2 of the 2016 revised IRR of RA No. 9184 allowing the GPPB to amend the IRR, which shall be applied to all procurement activities, the advertisement, posting, or invitation of which were issued after the effectivity of the said amendment.

Additional requirements for the completion of this Contract shall be provided in the **Special Conditions of Contract (SCC)**.

## 2. Advance Payment and Terms of Payment

2.1. Advance payment of the contract amount is provided under Annex “D” of the revised 2016 IRR of RA No. 9184.

2.2. The Procuring Entity is allowed to determine the terms of payment on the partial or staggered delivery of the Goods procured, provided such partial payment shall correspond to the value of the goods delivered and accepted in accordance with prevailing accounting and auditing rules and regulations. The terms of payment are indicated in the **SCC**.

## 3. Performance Security

Within ten (10) calendar days from receipt of the Notice of Award by the Bidder from the Procuring Entity but in no case later than prior to the signing of the Contract by both parties, the successful Bidder shall furnish the performance security in any of the forms prescribed in Section 39 of the 2016 revised IRR of RA No. 9184

## 4. Inspection and Tests

The Procuring Entity or its representative shall have the right to inspect and/or to test the Goods to confirm their conformity to the Project *{[Include if Framework Agreement will be used:]* or Framework Agreement} specifications at no extra cost to the Procuring Entity in accordance with the Generic Procurement Manual. In addition to tests in the **SCC, Section IV (Technical Specifications)** shall specify what inspections and/or tests the Procuring Entity requires, and where they are to be conducted. The Procuring Entity shall notify the Supplier in writing, in a timely manner, of the identity of any representatives retained for these purposes.

All reasonable facilities and assistance for the inspection and testing of Goods, including access to drawings and production data, shall be provided by the Supplier to the authorized inspectors at no charge to the Procuring Entity.

## **5. Warranty**

5.1 In order to assure that manufacturing defects shall be corrected by the Supplier, a warranty shall be required from the Supplier as provided under Section 62.1 of the 2016 revised IRR of RA No. 9184.

5.2 The Procuring Entity shall promptly notify the Supplier in writing of any claims arising under this warranty. Upon receipt of such notice, the Supplier shall, repair or replace the defective Goods or parts thereof without cost to the Procuring Entity, pursuant to the Generic Procurement Manual.

## **6. Liability of the Supplier**

The Supplier's liability under this Contract shall be as provided by the laws of the Republic of the Philippines.

If the Supplier is a joint venture, all partners to the joint venture shall be jointly and severally liable to the Procuring Entity.

## *Section V. Special Conditions of Contract*

## Special Conditions of Contract

GCC Clause	
1	The Procuring Entity is <i>The Philippine International Convention Center (PICC)</i>
2.2	<p><b>Payment</b></p> <ol style="list-style-type: none"> <li>1. Full payment shall be made upon completion of the project and submission of the following documents: <ul style="list-style-type: none"> <li>• Letter request of the Contractor for the release of the payment for work accomplished</li> <li>• Breakdown of work accomplished as validated and certified by PICC Representative</li> <li>• Photographs of work accomplished</li> <li>• As-Built Plan in soft and hard copy. The hard copy shall be in A3 bond size, three (3) copies signed by the CONTRACTOR and PICC authorized representative. The soft copy shall be saved in a USB.</li> <li>• Invoice</li> </ul> </li> <li>2. Full payment shall be subject to the following: <ul style="list-style-type: none"> <li>• Five percent (5%) of the Contract amount as retention money. The total “retention money” shall be due for release upon final acceptance of the works or after one (1) year from date of turn-over and acceptance of the project.</li> </ul> </li> <li>3. The PICC representative shall check the Contractor’s request for payment and certify the amount to be paid to the Contractor. Materials and equipment delivered on the site but not completely put in place shall not be included for payment.</li> <li>4. The PICC shall deduct the following from the certified gross amounts to be paid to the contractor’s full payment. <ul style="list-style-type: none"> <li>• 5% as Retention money</li> <li>• Amount to cover the third party liabilities</li> </ul> </li> </ol>

3	<p>Performance Security</p> <p>Within ten (10) calendar days from receipt of the Notice of Award, but in no case later than the signing of the contract by both parties, the successful Bidder shall furnish the performance security in any of the following forms:</p> <table border="1" data-bbox="371 421 1380 958"> <thead> <tr> <th data-bbox="371 421 906 533">Form of Performance Security</th> <th data-bbox="906 421 1380 533">Amount of Performance Security (Equal to Percentage of the Total Contract Price)</th> </tr> </thead> <tbody> <tr> <td data-bbox="371 533 906 645">Cash or Cashier's/Manager's Check issued by a Universal or Commercial Bank.</td> <td data-bbox="906 533 1380 645">Five percent (5%)</td> </tr> <tr> <td data-bbox="371 645 906 741">Bank draft/guarantee issued by a Universal or Commercial Bank</td> <td data-bbox="906 645 1380 741">Five percent (5%)</td> </tr> <tr> <td data-bbox="371 741 906 958">Surety bond callable upon demand issued by a surety or insurance company duly certified by the Insurance Commission as authorized to issue such security.</td> <td data-bbox="906 741 1380 958">Thirty percent (30%)</td> </tr> </tbody> </table>	Form of Performance Security	Amount of Performance Security (Equal to Percentage of the Total Contract Price)	Cash or Cashier's/Manager's Check issued by a Universal or Commercial Bank.	Five percent (5%)	Bank draft/guarantee issued by a Universal or Commercial Bank	Five percent (5%)	Surety bond callable upon demand issued by a surety or insurance company duly certified by the Insurance Commission as authorized to issue such security.	Thirty percent (30%)
Form of Performance Security	Amount of Performance Security (Equal to Percentage of the Total Contract Price)								
Cash or Cashier's/Manager's Check issued by a Universal or Commercial Bank.	Five percent (5%)								
Bank draft/guarantee issued by a Universal or Commercial Bank	Five percent (5%)								
Surety bond callable upon demand issued by a surety or insurance company duly certified by the Insurance Commission as authorized to issue such security.	Thirty percent (30%)								
5	<p>Warranty</p> <p>The warranty period shall be <b>Three (3) year</b> reckoned from the date of final turn-over and acceptance. The obligation for the warranty shall be covered by either <b>retention money</b> equivalent to five (5) percent of the total contract amount or a <b>special bank guarantee</b> equivalent to five (5) percent of the total contract amount. Said amounts shall only be released after the lapse of the warranty period.</p>								
6	<p>The period for correction of defects is seven (7) calendar days upon receipt of notice from PICC project-in-charge.</p>								
	<p><b>LIQUIDATED DAMAGES:</b></p> <p>In case of delay in the completion period inclusive of duly granted time extensions, if any, the Contractor shall be liable for damages and shall pay the PICC for liquidated damages in an amount equivalent to at least one tenth (1/10) of one percent (1%) of the cost of the unperformed works/services for every day of delay.</p> <p>The maximum deduction shall be ten percent (10%) of the amount of contract. Once the cumulative amount of liquidated damages reaches ten percent (10%) of the amount of the Contract, the procuring entity may rescind the award without prejudice to other courses of action and remedies open to it.</p>								

## *Section VI. Schedule of Requirements*

The delivery schedule expressed as weeks/months stipulates hereafter a delivery date which is the date of delivery to the project site.

Item Number	Description	
I	Supply of Labor and Materials for the Replacement of Bullet Resistant Glass Doors of Heroes Room	Work shall be completed within ninety (90) calendar days reckoned seven (7) calendar days from the receipt of the Notice to Proceed

I hereby commit to comply and deliver all the above requirements in accordance with the above stated schedule.

\_\_\_\_\_  
Name of Company / Bidder

\_\_\_\_\_  
Signature over printed Name of Authorized Representative

\_\_\_\_\_  
Position

\_\_\_\_\_  
Date





## *Section VII. Technical Specifications*

# Technical Specifications

Item	Specification	Statement of Compliance																																										
	<p><b>SUPPLY OF LABOR AND MATERIALS FOR THE REPLACEMENT OF THE BULLET RESISTANT GLASS DOORS OF HEROES ROOM</b></p> <p><b>I. SCOPE OF WORKS and SPECIFICATIONS:</b></p> <p>The works shall be supply of all materials, labor, tools, equipment and other incidental necessary for the replacement of the bullet resistant glass doors of the subject project.</p> <p>The following features of the work shall be performed, but not limited to the following:</p> <ol style="list-style-type: none"> <li>1. Mobilization Manpower, tools, equipment and temporary warehouse.</li> <li>2. Health and Safety requirements               <ol style="list-style-type: none"> <li>a. Installation of safety signage, same as the PICC standard signage 22" x 32".</li> <li>b. Personal Protective Equipment (PPE). The Contractor shall comply with the protocol against COVID-19. All workers shall wear their company uniform together with the required PPEs.</li> </ol> </li> <li>3. Replacement of bullet resistant glass doors at Heroes Room:               <ol style="list-style-type: none"> <li>a. Dismantling of existing bullet resistant glass doors and frames, see attached plan for details.</li> <li>b. Supply and installation of door jamb and glass frame. The materials to be used shall be 304 stainless tubular steel-1.5mm thick with 304 stainless steel reinforced with tubular-2mm thick, color- black titanium brushed matte, see attached plan for details.</li> <li>c. Supply and installation of bullet resistant glass. The bullet resistant glass shall be 25mm thick and compliant to National Institute of Justice (NIJ) 0108.01, Level II.</li> </ol> </li> </ol>																																											
	<table border="1" style="width: 100%; border-collapse: collapse; text-align: center;"> <thead> <tr> <th colspan="3">Test Variables</th> <th colspan="4">Performance Requirements</th> </tr> <tr> <th>Armor Type</th> <th>Test Ammunition</th> <th>Nominal Bullet Mass</th> <th>Suggested Barrel Length</th> <th>Required Bullet Velocity</th> <th>Required Hits Per Armor Specimen</th> <th>Permitted Penetrations</th> </tr> </thead> <tbody> <tr> <td>II</td> <td>357 Magnum</td> <td>10.2 g</td> <td>15 to 16.5 cm</td> <td>425 ± 15 m/s</td> <td>5</td> <td>0</td> </tr> <tr> <td></td> <td>JSP</td> <td>158 gr</td> <td>6 to 6.5 in</td> <td>1395 ± 50 ft/s</td> <td></td> <td></td> </tr> <tr> <td></td> <td>9mm</td> <td>8.0 g</td> <td>10 to 12 cm</td> <td>358 ± 12m/s</td> <td>5</td> <td>0</td> </tr> <tr> <td></td> <td>FMJ</td> <td>124 gr</td> <td>4 to 4.75 in</td> <td>1175 ± 40 ft/s</td> <td></td> <td></td> </tr> </tbody> </table> <p>* JSP – Jacketed Soft Point * FMJ – Full Metal Jacket</p>	Test Variables			Performance Requirements				Armor Type	Test Ammunition	Nominal Bullet Mass	Suggested Barrel Length	Required Bullet Velocity	Required Hits Per Armor Specimen	Permitted Penetrations	II	357 Magnum	10.2 g	15 to 16.5 cm	425 ± 15 m/s	5	0		JSP	158 gr	6 to 6.5 in	1395 ± 50 ft/s				9mm	8.0 g	10 to 12 cm	358 ± 12m/s	5	0		FMJ	124 gr	4 to 4.75 in	1175 ± 40 ft/s			
Test Variables			Performance Requirements																																									
Armor Type	Test Ammunition	Nominal Bullet Mass	Suggested Barrel Length	Required Bullet Velocity	Required Hits Per Armor Specimen	Permitted Penetrations																																						
II	357 Magnum	10.2 g	15 to 16.5 cm	425 ± 15 m/s	5	0																																						
	JSP	158 gr	6 to 6.5 in	1395 ± 50 ft/s																																								
	9mm	8.0 g	10 to 12 cm	358 ± 12m/s	5	0																																						
	FMJ	124 gr	4 to 4.75 in	1175 ± 40 ft/s																																								

**NIJ STANDARD: TEST METHOD**

**Type II Test Weapon and Ammunition**

**Higher Velocity 357 Magnum:** The test weapon may be a 357 Magnum handgun or test barrel. The use of a handgun with a 15 to 16.5 cm (6 to 6.5 in) barrel is suggested. Test Bullets shall be 357 Magnum soft point, with nominal masses of 10.2 g (158gr) and measured velocities of  $425 \pm 15$  m ( $1395 \pm 50$  ft) per second.

**Higher Velocity 9 mm:** The test weapon may be a 9 mm handgun or test barrel. The use of a handgun with a 10 to 12 cm (4 to 4.75 in) barrel is suggested. Test Bullets shall be 9 mm full metal jacketed, with nominal masses of 8.0 g (124 gr) and measured velocities of  $358 \pm 12$  m ( $1175 \pm 40$  ft) per second.

- d. Supply and installation of two (2) heavy duty door closers, with hold and open features. Submit EN 1154 certificate of compliance. Submit brochure of door closer before installation for approval.
- e. Supply and installation of mortise lockset, stainless steel with four (4) sliding deadbolts plus one (1) spring bolt, measuring 240mm (Height) x 30mm (Width). Submit brochure of mortise lockset before installation for approval.
- f. Supply and installation of vertical locks, top and bottom, embedded into the door frame, solid stainless steel, spring-loaded, at least 304mm (length) with 10mm solid stainless steel round bolts.
- g. Supply and installation of heavy duty solid stainless steel hinges. 5 pcs. per door. Submit brochure of the hinges before installation for approval.

Hinge Specification:

	Capacity (kg)	Length (mm)	Width (mm)	Thickness (mm)
1 hinge	80	165	40	3

- h. Supply and installation of two (2) pcs. 304 stainless steel handle to be mounted over the mortise lockset. Submit brochure of mortise lockset before installation for approval.
- 4. Restoration work.
  - 5. Hauling of dismantled bullet resistant glass doors and frames at PICC- workshop.
  - 6. Demobilization  
Manpower, tools, equipment, temporary warehouse, including hauling-out of construction debris.
  - 7. Submission of Certificate from Research Development Center of the Philippine Army (RDC-PA) and Evaluation Sample
    - a. The Contractor shall submit a 1 ft. x 1 ft. sample of the glass to be used. The sample shall be considered compliant and acceptable from RDC-PA stating that the submitted sample passed the testing of NIJ0108.01 Level 2.

- b. The *compliant* sample and RDC-PA certificate must be submitted within ten (10) calendar days from receipt of the *Notice of Proceed*

## II. GENERAL CONDITIONS:

1. The Contract Documents, Specifications and Drawings are mutually complimentary. What is noted in one although not shown in other shall be considered contained in all, in case of conflict. The Specifications shall prevail over the Drawings. The documents forming the Contract shall be interpreted in the following order of priority:
  - a. Contract/Construction Agreement
  - b. Contractor's Bid
  - c. Special Conditions of the Contract
  - d. Specifications
  - e. Drawings
  - f. Any other document listed in the Special Conditions of the Contract as forming part of the Contract
2. The Bidders shall examine all the issued documents relating to the work and must have verified all the existing conditions at the site. No consideration will be given for any alleged misunderstanding or misinterpretation of the specifications and materials to be used or work to be done.
3. The Bidders shall inspect and examine the site and the surroundings of the project to arrive at a reasonable estimate of the labor, materials, equipment, facilities and services necessary to carry out the works.
4. Tapping of equipment and other related works at the temporary facilities shall be properly coordinated with PICC Representative for provision of electrical power and water. For this purpose, the CONTRACTOR shall provide a sub-meter for power and water consumptions and shall be billed accordingly to the total kilowatt and volume utilized.
5. The Lowest Complying Bidder (LCB) shall submit 1 ft. x 1 ft. sample of resistant bulletproof glass to be tested for NIJ 0108.01 Level 2, at the Research and Development Center of Philippine Army (RDC-PA). Testing to be witnessed by two (2) representative from the end-user and one (1) representative from the contractor. The cost of testing should be covered by the LCB. The passed and approved sample shall be retained by the end-user as its control sample.
6. The contractor must provide certificate from the bulletproof resistant glass manufacturer that the delivered bulletproof resistant glass is exactly the same in design and structure as the passed and approved sample.

## III. CONTRACTOR'S OBLIGATION:

1. The CONTRACTOR shall perform all works necessary to fully accomplish the project.

2. The CONTRACTOR shall provide the following key personnel:

Key Personnel	Relevant Experience
Project Supervisor – Civil or Mechanical Engineer	Must have managed/supervised a completed project involving glass works.
Safety Officer	Minimum of three (3) years' work experience as Safety Officer/Practitioner. Must have Certificate of employment as Safety Officer and Certificate of training in Occupational Safety and Health from DOLE or any DOLE accredited training institution.

3. The CONTRACTOR shall commence execution of the works on the Start Date and shall carry out the works in accordance with the program of work submitted by the CONTRACTOR, as updated with the approval of PICC Representative and complete them by the intended completion date
4. The CONTRACTOR shall provide all supervision, labor, materials, plant and Contractor's equipment, which may be required.
5. The CONTRACTOR shall be liable to all health hazards for its workers, fire and accident claims and other related claims arising from the injuries and damages, which occurred in the vicinity. The Contractor shall submit a Safety and Health Program signed by the Contractor and its Safety Officer. The Contractor shall provide PPEs of its workers. No workers shall be allowed to work on site without PPEs like safety shoes, reflective vest and other necessary protective equipment as protection against COVID-19.
6. The CONTRACTOR shall free the PICC and its personnel from and against all liability for damages arising from injuries or liabilities to persons or damages to property by any act of omissions of the contractor including any and all expenses which may be incurred by its personnel in the defense of any claim, action or suit.
7. Any work that may affect the operation, security and image of the Center shall be coordinated properly with PICC Representative and shall be done in accordance with the Center's approved schedule.
8. Cost of rework and restoration or replacement of all damaged properties due to CONTRACTOR'S poor workmanship or negligence shall be borne by the Contractor.
9. The CONTRACTOR shall submit list of personnel assigned to the project including their NBI clearance before commencing the above scope of works.

10. The CONTRACTOR's personnel/workers must wear at all times their PPE, security ID issued by PICC and uniform while working inside the Center.

11. The CONTRACTOR shall provide three (3) years warranty certificate for the bullet resistant glass and its frame, including sagging and delamination of glass.

**IV. WORKMANSHIP:**

The work throughout shall be executed in the best and most thorough manner to the satisfaction of PICC and its engineers and supervisors who will jointly interpret the meaning of the scope of work and its conditions and shall have the power to reject any work, method of accomplishing every part of work and material used which in their judgment are not in full accordance therewith and are disadvantageous to PICC.

**STATEMENT OF COMPLIANCE**

*Bidders must state here either "Comply" or "Not Comply" against each of the individual parameters of each Specification stating the corresponding performance parameter of the equipment offered.*

*Statements of "Comply" or "Not Comply" must be supported by evidence in a Bidders Bid and cross-referenced to that evidence. Evidence shall be in the form of manufacturer's un-amended sales literature, unconditional statements of specification and compliance issued by the manufacturer, samples, independent test data etc., as appropriate. A statement that is not supported by evidence or is subsequently found to be contradicted by the evidence presented will render the Bid under evaluation liable for rejection. A statement either in the Bidder's statement of compliance or the supporting evidence that is found to be false either during Bid evaluation, post-qualification or the execution of the Contract may be regarded as fraudulent and render the Bidder or supplier liable for prosecution subject to the applicable laws and issuances.*

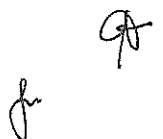



**PICC**  
 CONSULTING  
 ARCHITECTS

PLENARY / RECEPTION LOBBY

REPLACEMENT OF THE  
 BULLET RESISTANT GLASS  
 DOOR OF THE HEROES ROOM

UTILITY  
 ROOM

TO PLENARY AND  
 RECEPTION HALL  
 LOBBY

PANTRY

COMFORT  
 ROOM

VESTIBULE

GLASS

HEROES ROOM

HALLWAY TO RECEPTION HALL

STORAGE  
 ROOM 1

RAMP UP

BRIDGEWAY

EMERGENCY  
 EXIT



**LOCATION PLAN**

SCALE 1 : 70 M.

DATE	REVISION	DESIGNED BY	RECOMMENDED / APPROVED	APPROVED BY	SHEET NO.
10. 02. 2022	11. 03. 2022	AR. BENJAMIN B. MENDOZA JR. ARCHITECT	MR. ROBERTO A. GARCIA SENIOR GENERAL MANAGER	ATTY. REYNOLDO B. MACHUCA SENIOR MANAGER	1
SUPPLY OF LABOR AND MATERIALS FOR THE REPLACEMENT OF THE BULLET RESISTANT GLASS DOORS OF HEROES ROOM		CHECKED BY			2
PICC COMPLEX		ENGINEER			
LOUJE JAY E. GARDON ARCHITECT		ASSISTANT DIRECTOR, RPD-30			

PROVIDE 2.0mm THK, COLOR - BLACK TITANIUM BRUSHED MATTE TUBULAR TO REINFORCED THE DOOR FRAME

25mm THK. BULLET RESISTANT GLASS

1.5mm THK 304 STAINLESS STEEL BLACK TITANIUM BRUSHED MATTE DOOR FRAME WITH 2 HEAVY DUTY DOOR CLOSER (WITH HOLD AND OPEN FEATURES), MORISE LOCKSET - 4 SLIDING STAINLESS STEEL BOLTS PLUS 1 SPRING BOLTS, VERTICAL LOCKS EMBEDDED INTO THE DOOR FRAME, 5 PCS HEAVY DUTY SOLID STAINLESS HINGES PER DOOR AND STAINLESS STEEL HANDLES

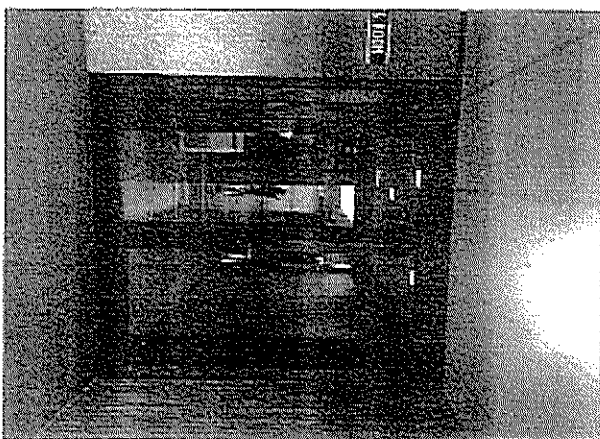

EXISTING DOOR

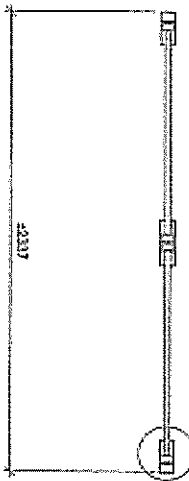
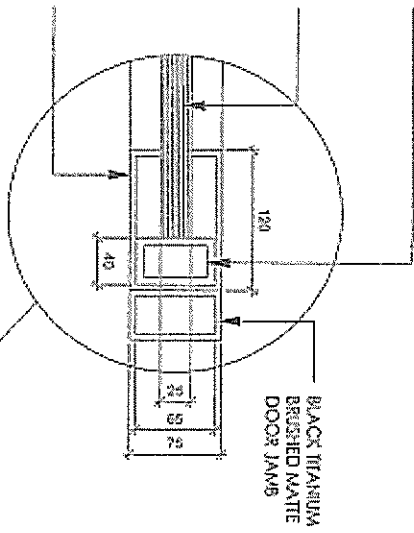

NOTE: VERIFY ACTUAL DIMENSION

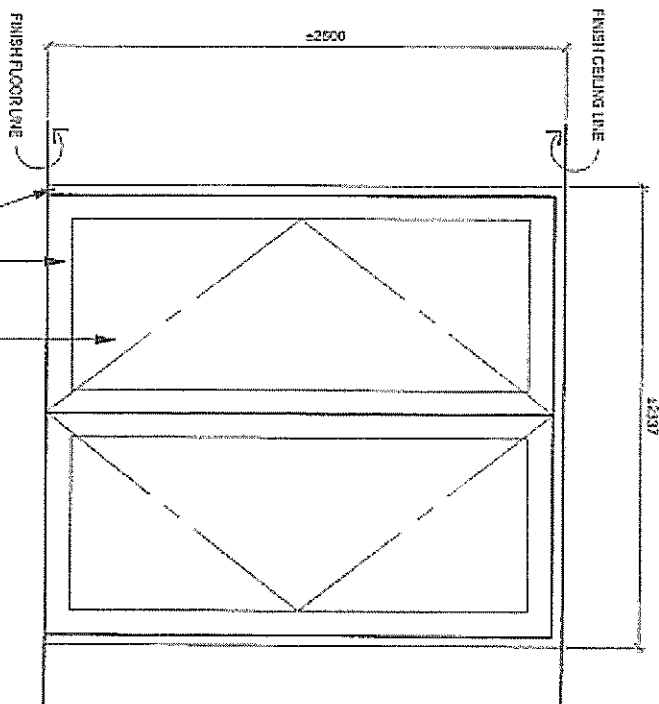

1.5mm THK 304 STAINLESS STEEL BLACK TITANIUM BRUSHED MATTE DOOR FRAMES AND JAMB, THE JAMB SHALL BE INSTALLED AND FIXED TO THE EXISTING STRUCTURE. PROVIDE NECESSARY BOLTS AND SCREWS AND ACCESSORIES TO HOLD AND SECURE THE JAMBS.

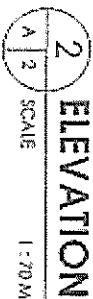

<p>PICC PROCESSES</p>	<b>TITLE</b> SUPPLY OF LABOR AND MATERIALS FOR THE REPLACEMENT OF THE BULLET RESISTANT GLASS DOORS OF HEROES ROOM		<b>DATE</b> 10. 03. 2022		<b>REVISION</b> 11. 03. 2022		<b>DESIGNED BY</b> MRS. RUTH MENDOZA, JR. SENIOR SERVICES OFFICER		<b>CHECKED BY</b> ENGR. EDUARDO A. GARCIA ASSISTANT DESIGNER		<b>APPROVED BY</b> MR. EDUARDO A. GARCIA SENIOR GENERAL MANAGER		<b>DATE</b> 11. 03. 2022	
	<b>LOCATION</b> PICC COMPLEX		<b>ADVISOR</b> LOVE JAY E. GARDON ASSISTANT CHIEF		<b>DESIGNED BY</b> MRS. RUTH MENDOZA, JR. SENIOR SERVICES OFFICER		<b>CHECKED BY</b> ENGR. EDUARDO A. GARCIA ASSISTANT DESIGNER		<b>APPROVED BY</b> MR. EDUARDO A. GARCIA SENIOR GENERAL MANAGER		<b>DATE</b> 11. 03. 2022		<b>SHEET NO.</b> 2 / 2	



*Section VIII. Checklist of Technical and  
Financial Documents*

# Checklist of Technical and Financial Documents

## I. TECHNICAL COMPONENT ENVELOPE

### *Class "A" Documents*

#### Legal Documents

- (a) Certified Photocopy of the Valid PhilGEPS Registration Certificate (Platinum Membership) (all pages); if any of the documents mentioned in Annex "A" is not current, the new document should be submitted  
**Or** in case of expired PhilGEPS Registration Certificate (Platinum Membership);
- (b) Registration certificate from Securities and Exchange Commission (SEC), Department of Trade and Industry (DTI) for sole proprietorship, or Cooperative Development Authority (CDA) for cooperatives or its equivalent document,  
**and**
- (c) Mayor's or Business permit issued by the city or municipality where the principal place of business of the prospective bidder is located, or the equivalent document for Exclusive Economic Zones or Areas;  
**and**
- (d) Tax clearance per E.O. No. 398, s. 2005, as finally reviewed and approved by the Bureau of Internal Revenue (BIR).

Provided, that the current PhilGEPS Registration Certificate (Platinum Membership) shall be part of the post-qualification documents to be submitted by the Lowest Calculated Bidder

#### Technical Documents

- (e) Statement of the prospective bidder of all its ongoing government and private contracts, including contracts awarded but not yet started, if any, whether similar or not similar in nature and complexity to the contract to be bid (*Annex "A"*); **and**
- (f) Statement of the bidder's Single Largest Completed Contract (SLCC) similar to the contract to be bid, except under conditions provided for in Sections 23.4.1.3 and 23.4.2.4 of the 2016 revised IRR of RA No. 9184, within the relevant period as provided in the Bidding Documents (*Annex "B"*); **and**
- (g) Original copy of Bid Security. If in the form of a Surety Bond, submit also a certification issued by the Insurance Commission;  
**or**  
Original copy of Notarized Bid Securing Declaration (*Annex "C"*); **and**
- (h) Fully accomplished Section VI (Schedule of Delivery Requirements) and Section VII (Technical Specifications), signed on each and every page; **and**
- (i) Original duly signed Omnibus Sworn Statement (OSS)(*Annex "D"*); **and** if applicable, Original Notarized Secretary's Certificate in case of a corporation, partnership, or cooperative; or Original Special Power of Attorney of all members of the joint venture giving full power and authority to its officer to sign the OSS and do acts to represent the Bidder.

Financial Documents

- (j) The Supplier's audited financial statements, showing, among others, the Supplier's total and current assets and liabilities, stamped "received" by the BIR or its duly accredited and authorized institutions, for the immediately preceding calendar year; **and**
- (k) The prospective bidder's computation of Net Financial Contracting Capacity (NFCC) (*Annex "E"*);  
**or**  
A committed Line of Credit from a Universal or Commercial Bank in lieu of its NFCC computation.

*Class "B" Documents*

- (l) If applicable, a duly signed joint venture agreement (JVA) in case the joint venture is already in existence;  
**or**  
duly notarized statements from all the potential joint venture partners stating that they will enter into and abide by the provisions of the JVA in the instance that the bid is successful.

**II. FINANCIAL COMPONENT ENVELOPE**

- (m) Original of duly signed and accomplished Financial Bid Form;
- (n) Original of duly signed and accomplished Bill of Quantities.

**List of all Ongoing Government & Private Contracts including contracts awarded but not yet started**

Business Name : \_\_\_\_\_  
 Business Address : \_\_\_\_\_

Name of Contract/ Project Cost	a. Owner's Name b. Address c. Telephone Nos.	Nature of Work	Bidder's Role		a. Date Awarded b. Date Started c. Date of Completion	% of Accomplishment		Value of Outstanding Works / Undelivered
			Description	%		Planned	Actual	
Government								
Private								
<b>Total Cost</b>								

Submitted by : \_\_\_\_\_  
 (Printed Name & Signature)  
 Designation : \_\_\_\_\_  
 Date : \_\_\_\_\_

ANNEX "B"

**SINGLE LARGEST COMPLETED CONTRACT**  
WHICH IS SIMILAR TO THE CONTRACT TO BE BID

Business Name:

Business Address:

Name of Contract	a. Owner' Name b. Address c. Telephone Nos.	Nature of Item/Service	a. Amount of Award b. Amount at Completion c. Duration	a. Date Awarded b. Contract Effectivity c. Date Completed

Note: This statement shall be supported with:

1. Contract
2. Certificate of Completion & Acceptance or Official Receipt/s or Sales Invoice issued for the contract

*Note: The Single Largest Completed Contract shall be completed within the last ten (10) years from the date of submission and receipt of bids, that is similar to the contract to be bid, the amount of which shall be at least fifty percent (50%) of the ABC.*

Submitted by:

\_\_\_\_\_

(Printed Name & Signature)

Designation:

\_\_\_\_\_

Date:

\_\_\_\_\_

**BID SECURING DECLARATION FORM**

---

REPUBLIC OF THE PHILIPPINES)  
CITY OF \_\_\_\_\_) S.S.

x-----x

**BID SECURING DECLARATION**  
**Invitation to Bid:** *[Insert Reference number]*

To: *[Insert name and address of the Procuring Entity]*

I/We<sup>2</sup>, the undersigned, declare that:

1. I/We understand that, according to your conditions, bids must be supported by a Bid Security, which may be in the form of a Bid-Securing Declaration.
2. I/We accept that: (a) I/we will be automatically disqualified from bidding for any contract with any procuring entity for a period of two (2) years upon receipt of your Blacklisting order; and, (b) I/we will pay the applicable fine provided under Section 6 of the Guidelines on the Use of Bid Securing Declaration, within fifteen (15) days from receipt of the written demand by the procuring entity for the commission of acts resulting to the enforcement of the bid securing declaration under Sections 23.1(b), 34.2, 40.1 and 69.1, except 69.1(f), of the IRR of RA 9184; without prejudice to other legal action the government may undertake.
3. I/We understand that this Bid Securing Declaration shall cease to be valid on the following circumstances:
  - (a) Upon expiration of the bid validity period, or any extension thereof pursuant to your request;
  - (b) I am/we are declared ineligible or post-disqualified upon receipt of your notice to such effect, and (i) I/we failed to timely file a request for reconsideration or (ii) I/we filed a waiver to avail of said right;
  - (c) I am/we are declared the bidder with the Lowest Calculated Responsive Bid, and I/we have furnished the performance security and signed the Contract.

---

<sup>2</sup> Select one and delete the other. Adopt the same instruction for similar terms throughout the document.

IN WITNESS WHEREOF, I/We have hereunto set my/our hand/s this \_\_\_\_ day of [month] [year] at [place of execution].

*[Insert NAME OF BIDDER'S AUTHORIZED REPRESENTATIVE]*

*[Insert Signatory's Legal Capacity]*

Affiant

**SUBSCRIBED AND SWORN** to before me this \_\_\_\_ day of [month] [year] at [place of execution], Philippines. Affiant/s is/are personally known to me and was/were identified by me through competent evidence of identity as defined in the 2004 Rules on Notarial Practice (A.M. No. 02-8-13-SC). Affiant/s exhibited to me his/her [insert type of government identification card used], with his/her photograph and signature appearing thereon, with no. \_\_\_\_\_ and his/her Community Tax Certificate No. \_\_\_\_\_ issued on \_\_\_\_ at \_\_\_\_\_.

Witness my hand and seal this \_\_\_\_ day of [month] [year].

**NAME OF NOTARY PUBLIC**

Serial No. of Commission \_\_\_\_\_

Notary Public for \_\_\_\_\_ until \_\_\_\_\_

Roll of Attorneys No. \_\_\_\_\_

PTR No. \_\_\_\_\_ [date issued], [place issued]

IBP No. \_\_\_\_\_ [date issued], [place issued]

Doc. No. \_\_\_\_\_

Page No. \_\_\_\_\_

Book No. \_\_\_\_\_

Series of \_\_\_\_\_

## *Omnibus Sworn Statement (Revised)*

*[shall be submitted with the Bid]*

---

REPUBLIC OF THE PHILIPPINES)  
CITY/MUNICIPALITY OF \_\_\_\_\_) S.S.

### AFFIDAVIT

I, [Name of Affiant], of legal age, [Civil Status], [Nationality], and residing at [Address of Affiant], after having been duly sworn in accordance with law, do hereby depose and state that:

1. *[Select one, delete the other:]*

*[If a sole proprietorship:]* I am the sole proprietor or authorized representative of [Name of Bidder] with office address at [address of Bidder];

*[If a partnership, corporation, cooperative, or joint venture:]* I am the duly authorized and designated representative of [Name of Bidder] with office address at [address of Bidder];

2. *[Select one, delete the other:]*

*[If a sole proprietorship:]* As the owner and sole proprietor, or authorized representative of [Name of Bidder], I have full power and authority to do, execute and perform any and all acts necessary to participate, submit the bid, and to sign and execute the ensuing contract for [Name of the Project] of the [Name of the Procuring Entity], as shown in the attached duly notarized Special Power of Attorney;

*[If a partnership, corporation, cooperative, or joint venture:]* I am granted full power and authority to do, execute and perform any and all acts necessary to participate, submit the bid, and to sign and execute the ensuing contract for [Name of the Project] of the [Name of the Procuring Entity], as shown in the attached [state title of attached document showing proof of authorization (e.g., duly notarized Secretary's Certificate, Board/Partnership Resolution, or Special Power of Attorney, whichever is applicable)];

3. [Name of Bidder] is not "blacklisted" or barred from bidding by the Government of the Philippines or any of its agencies, offices, corporations, or Local Government Units, foreign government/foreign or international financing institution whose blacklisting rules have been recognized by the Government Procurement Policy Board, **by itself or by relation, membership, association, affiliation, or controlling interest with another blacklisted person or entity as defined and provided for in the Uniform Guidelines on Blacklisting;**

4. Each of the documents submitted in satisfaction of the bidding requirements is an authentic copy of the original, complete, and all statements and information provided therein are true and correct;

5. [Name of Bidder] is authorizing the Head of the Procuring Entity or its duly authorized representative(s) to verify all the documents submitted;



6. *[Select one, delete the rest:]*

*[If a sole proprietorship:]* The owner or sole proprietor is not related to the Head of the Procuring Entity, members of the Bids and Awards Committee (BAC), the Technical Working Group, and the BAC Secretariat, the head of the Project Management Office or the end-user unit, and the project consultants by consanguinity or affinity up to the third civil degree;

*[If a partnership or cooperative:]* None of the officers and members of *[Name of Bidder]* is related to the Head of the Procuring Entity, members of the Bids and Awards Committee (BAC), the Technical Working Group, and the BAC Secretariat, the head of the Project Management Office or the end-user unit, and the project consultants by consanguinity or affinity up to the third civil degree;

*[If a corporation or joint venture:]* None of the officers, directors, and controlling stockholders of *[Name of Bidder]* is related to the Head of the Procuring Entity, members of the Bids and Awards Committee (BAC), the Technical Working Group, and the BAC Secretariat, the head of the Project Management Office or the end-user unit, and the project consultants by consanguinity or affinity up to the third civil degree;

7. *[Name of Bidder]* complies with existing labor laws and standards; and

8. *[Name of Bidder]* is aware of and has undertaken the responsibilities as a Bidder in compliance with the Philippine Bidding Documents, which includes:

- a. Carefully examining all of the Bidding Documents;
- b. Acknowledging all conditions, local or otherwise, affecting the implementation of the Contract;
- c. Making an estimate of the facilities available and needed for the contract to be bid, if any; and
- d. Inquiring or securing Supplemental/Bid Bulletin(s) issued for the *[Name of the Project]*.

9. *[Name of Bidder]* did not give or pay directly or indirectly, any commission, amount, fee, or any form of consideration, pecuniary or otherwise, to any person or official, personnel or representative of the government in relation to any procurement project or activity.

**10. In case advance payment was made or given, failure to perform or deliver any of the obligations and undertakings in the contract shall be sufficient grounds to constitute criminal liability for Swindling (Estafa) or the commission of fraud with unfaithfulness or abuse of confidence through misappropriating or converting any payment received by a person or entity under an obligation involving the duty to deliver certain goods or services, to the prejudice of the public and the government of the Philippines pursuant to Article 315 of Act No. 3815 s. 1930, as amended, or the Revised Penal Code.**

IN WITNESS WHEREOF, I have hereunto set my hand this\_\_day of\_\_\_\_, 20\_\_at \_\_\_\_\_, Philippines.

*[Insert NAME OF BIDDER OR ITS AUTHORIZED REPRESENTATIVE]*

*[Insert signatory's legal capacity]*  
Affiant

**[Jurat]**

*[Format shall be based on the latest Rules on Notarial Practice]*

PHILIPPINE INTERNATIONAL CONVENTION CENTER

Name of the Project: **Supply of Labor and Materials for the Replacement of Bullet Resistant Glass Doors of Heroes Room**

**FINANCIAL DOCUMENTS FOR ELIGIBILITY CHECK**

A. Summary of the Applicant Supplier's/Distributor's/Manufacturer's assets and liabilities on the basis of the attached Income Tax Return and Audited Financial Statement, stamped "RECEIVED" by the Bureau of Internal Revenue or BIR authorized collecting agent, for the immediately preceding year and a certified copy of Schedule of Fixed Assets particularly the list of construction equipment.

		Year 20__
1.	Total Assets	
2.	Current Assets	
3.	Total Liabilities	
4.	Current Liabilities	
5.	Net Worth (1-3)	
6.	Net Working Capital (2-4)	
7.	Value of all outstanding or uncompleted portions of the project under ongoing contracts, including awarded contracts yet to be started coinciding with contract to be bid.	

B. The Net Financial Contracting Capacity (NFCC) based on the above data is computed as follows:

$NFCC = [(Current\ assets\ minus\ current\ liabilities)\ (15)]\ minus\ value\ of\ all\ outstanding\ or\ uncompleted\ portions\ of\ the\ project\ under\ ongoing\ contracts,\ including\ awarded\ contracts\ yet\ to\ be\ started\ coinciding\ with\ contract\ to\ be\ bid.$

NFCC = P \_\_\_\_\_

The values of the bidder's current assets and current liabilities shall be based on the data submitted to the BIR.

or

A committed Line of Credit, in an amount to at least ten percent (10%) of the ABC, issued by a Universal of Commercial Bank.

Submitted by:

\_\_\_\_\_  
Name of Supplier / Distributor / Manufacturer

\_\_\_\_\_  
Signature of Authorized Representative

Date: \_\_\_\_\_

Note:

1. If Partnership or Joint Venture, each Partner or Member Firm of Joint Venture shall submit the above requirements.

**BID FORM**

Date: \_\_\_\_\_

Project Identification No.: \_\_\_\_\_

To: *[name and address of Procuring Entity]*

Having examined the Philippine Bidding Documents (PBDs) including the Supplemental or Bid Bulletin Numbers *[insert numbers]*, the receipt of which is hereby duly acknowledged, we, the undersigned, offer to ***Supply of Labor and Materials for the Replacement of Bullet Resistant Glass Doors of Heroes Room*** sum of:

**TOTAL AMOUNT: INCLUSIVE OF VALUE ADDED TAX (VAT)**  
\_\_\_\_\_ (P \_\_\_\_\_)  
(Amount in Words) (Amount in figures)

or the total calculated bid price, as evaluated and corrected for computational errors, and other bid modifications in accordance with the Price Schedules attached herewith and made part of this Bid. The total bid price includes the cost of all taxes, such as, but not limited to: *[specify the applicable taxes, e.g. (i) value added tax (VAT), (ii) income tax, (iii) local taxes, and (iv) other fiscal levies and duties]*, which are itemized herein or in the Price Schedules (see attached),

If our Bid is accepted, we undertake:

- a. to deliver the services in accordance with the schedule specified in the Schedule of Requirements of the Philippine Bidding Documents (PBDs);
- b. to provide a performance security in the form, amounts, and within the times prescribed in the PBDs;
- c. to abide by the Bid Validity Period specified in the PBDs and it shall remain binding upon us at any time before the expiration of that period.

Until a formal Contract is prepared and executed, this Bid, together with your written acceptance thereof and your Notice of Award, shall be binding upon us.

We understand that you are not bound to accept the Lowest Calculated Bid or any Bid you may receive.

We certify/confirm that we comply with the eligibility requirements pursuant to the PBDs.

The undersigned is authorized to submit the bid on behalf of *[name of the bidder]* as evidenced by the attached *[state the written authority]*.

We acknowledge that failure to sign each and every page of this Bid Form, including the attached Schedule of Prices, shall be a ground for the rejection of our bid.

Name: \_\_\_\_\_

Legal capacity: \_\_\_\_\_

Signature: \_\_\_\_\_

Duly authorized to sign the Bid for and behalf of: \_\_\_\_\_

Date: \_\_\_\_\_

PROJECT : SUPPLY OF LABOR AND MATERIALS FOR THE REPLACEMENT OF THE BULLET RESISTANT GLASS DOORS OF HEROES ROOM  
 LOCATION : PICC COMPLEX, VICENTE SOTTO ST. PASAY CITY  
 DATE:

ITEM NO.	DESCRIPTION	QTY.	UNIT	UNIT DIRECT COST	ESTIMATED DIRECT COST	MARK-UPS OCM %	MARK-UPS PROFIT %	TOTAL MARK-UP %	VAT 12 %	TOTAL INDIRECT COST	TOTAL COST	UNIT COST
(1)	(2)	(3)	(4)	(5)	(6)	(7)	(8)	(10)	(12)	(13)	(14)	(15)
					(3 X 5)			(7 + 8)	12% (6 + 11)	(11 + 12)	(6 + 13)	(14/3)
<b>Part A - GENERAL REQUIREMENTS</b>												
A.1	General Requirements											
Mobilization include the following:												
A.1.1	Mobilization of manpower and equipments/tools. Water and power consumption Temporary warehouse,	1.00	lot									
A.1.2	Demobilization include the following: Demobilization of manpower and equipments/tools Hauling of debris outside PICC Temporary warehouse, bonds, etc.	1.00	lot									
<b>TOTAL PART A</b>												
<b>Part B - Architectural Works</b>												
B.1	Replacement of bullet proof doors											
B.1.1	Bulletproof glass main doors complete with fittings and hardware specified	1.00	lot									
<b>TOTAL PART B</b>												
<b>TOTAL A + B</b>												
<b>TOTAL CONSTRUCTION COST</b>												

Prepared by:

Name of Company:

Date: